

**Ergebnisse der Verkehrszählungen
im Rahmen des Projekts Untersuchung der Verkehrsverhältnisse
und Neukonzeption im Kernort der Wallfahrtsstadt Kevelaer**

Zusammenstellung der Zählungen und
Darstellung der DTV-Werte

Hilden, im November 2019

büro stadVerkehr





Anmerkungen zu den Verkehrsdaten

Folgende Aspekte sind zu berücksichtigen:

- Es handelt sich um eine erste Darstellung der Verkehrsdaten der Knotenpunkte 1-16 und der 13 Querschnitte.
- Für die Knotenpunkte wurden die Fahrzeugkategorien jeweils für die Zeiten zwischen 6:00 Uhr und 10:00 Uhr, sowie zwischen 15:00 Uhr und 19:00 Uhr richtungsscharf erfasst.
- Die Zählungen der Querschnitte sind komplett ganztägig (24h) richtungsscharf mit Videokameras erfasst worden.
- Die Berechnung der DTV-Werte erfolgte auf Grundlage der 24h-Zählung.

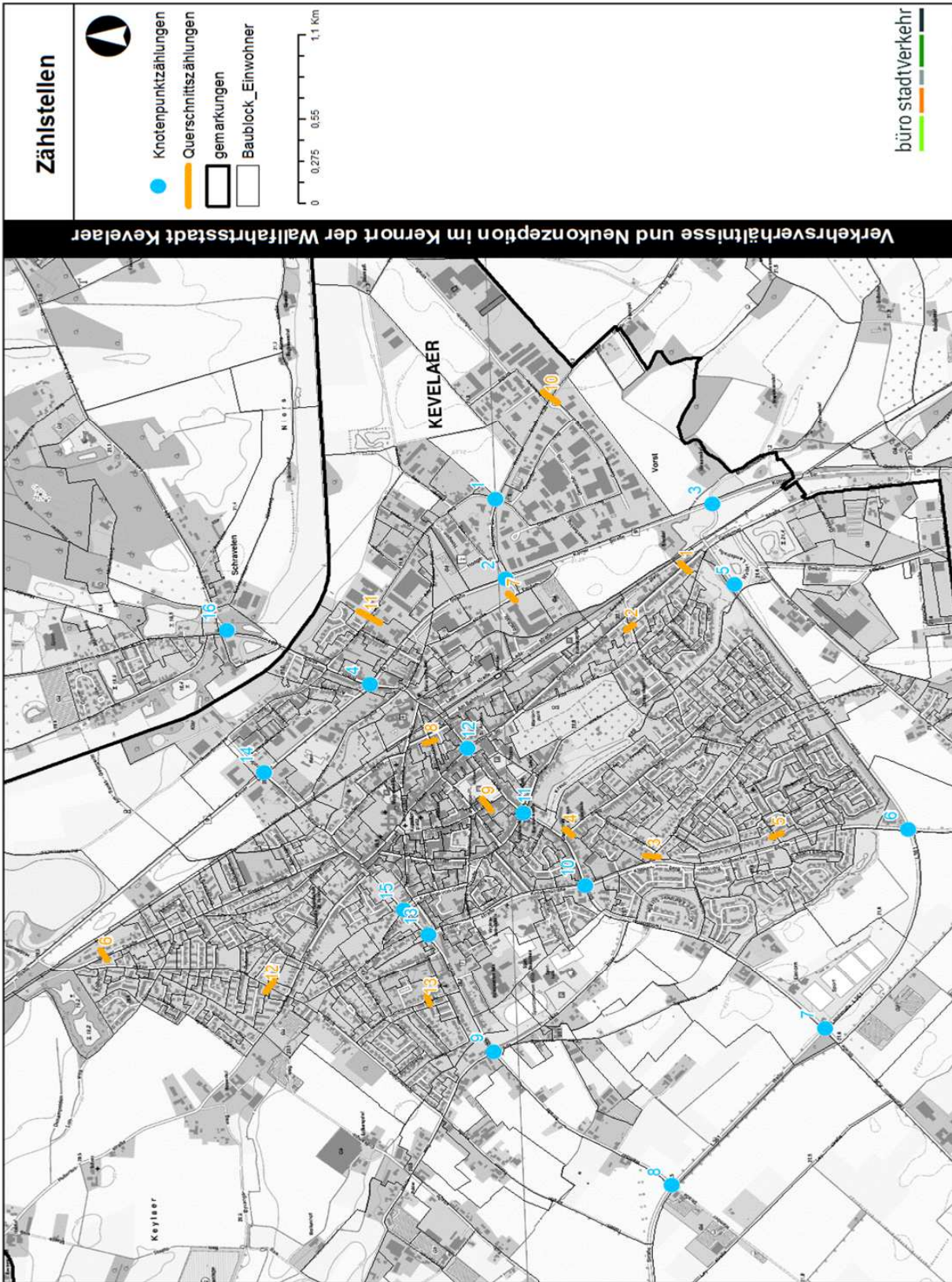

Knotenpunkt 1

Wettener Straße/ Gewerbering/ Hoogeweg

September 2019

2 mal 4 Stunden-Zählung

Datum der Zählung: Do. 17.09.2019

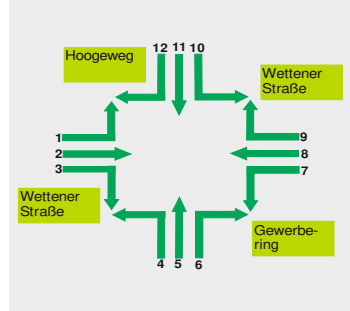

Intervall	Fz-Arten	Wettener Straße			Gewerbering			Wettener Straße			Hoogeweg		
		LA	GA	RA	LE	GE	RE	LA	GE	RA	LE	GE	RE
		1	2	3	4	5	6	7	8	9	10	11	12
06:00 - 06:15	PKW	3	8	14	0	0	0	3	10	4	1	11	4
	KRAD	0	1	0	0	0	0	0	0	0	0	0	0
	LIEFERWAGEN	1	2	1	3	7	2	0	1	1	0	2	1
	LKW	1	1	0	3	0	1	0	1	0	0	0	0
06:15 - 06:30	PKW	5	6	7	0	0	1	0	15	4	3	4	3
	KRAD	1	1	0	1	0	0	0	0	0	0	0	0
	LIEFERWAGEN	2	3	0	1	1	0	0	0	1	3	0	4
	LKW	0	1	0	3	0	1	1	0	2	0	0	1
06:30 - 06:45	PKW	16	22	16	2	0	0	1	14	1	2	8	5
	KRAD	0	0	0	0	0	0	0	0	0	0	0	1
	LIEFERWAGEN	3	5	2	0	2	1	3	1	2	0	0	4
	LKW	0	3	0	0	0	0	0	0	0	0	0	1
06:45 - 07:00	PKW	13	23	26	4	0	0	3	13	9	8	15	12
	KRAD	1	0	1	0	0	0	0	0	0	0	0	0
	LIEFERWAGEN	1	0	3	2	0	0	0	4	3	1	1	0
	LKW	0	2	0	4	1	1	0	1	0	1	0	2
07:00 - 07:15	PKW	19	24	18	3	3	0	2	14	9	8	5	12
	KRAD	0	1	2	0	0	0	0	0	0	0	0	0
	LIEFERWAGEN	3	5	3	2	2	0	2	4	1	2	1	2
	LKW	1	0	0	4	2	0	0	1	1	2	0	1
07:15 - 07:30	PKW	15	19	26	5	0	0	4	23	11	10	10	12
	KRAD	0	0	0	0	0	0	0	0	0	0	1	0
	LIEFERWAGEN	2	6	4	4	2	1	1	4	0	0	3	3
	LKW	3	2	1	1	1	1	0	3	0	0	0	3
07:30 - 07:45	PKW	30	18	18	6	2	0	6	30	4	7	8	24
	KRAD	1	1	2	0	0	0	0	3	0	0	0	0
	LIEFERWAGEN	1	4	1	2	1	0	0	10	3	1	2	2
	LKW	1	7	6	1	0	0	1	1	0	0	0	0
07:45 - 08:00	PKW	39	31	29	7	5	1	4	38	8	4	8	9
	KRAD	0	0	0	0	0	0	0	0	1	0	0	0
	LIEFERWAGEN	2	8	4	7	3	1	3	6	3	3	1	5
	LKW	1	2	4	3	0	0	1	0	1	1	0	2
08:00 - 08:15	PKW	23	17	20	5	1	3	1	13	6	15	3	19
	KRAD	0	0	0	0	0	0	0	0	0	0	0	0
	LIEFERWAGEN	4	3	1	2	2	1	2	2	1	0	0	1
	LKW	3	2	3	2	0	0	0	1	1	2	1	1
08:15 - 08:30	PKW	20	14	17	5	4	2	6	21	5	6	8	16
	KRAD	0	2	0	0	0	0	0	0	0	0	0	0
	LIEFERWAGEN	2	5	2	2	0	0	1	4	0	1	0	4
	LKW	1	5	0	4	0	0	0	4	1	1	3	3
08:30 - 08:45	PKW	14	18	16	8	5	2	3	22	2	8	9	7
	KRAD	0	0	1	0	0	0	0	0	0	0	0	0
	LIEFERWAGEN	3	1	3	7	4	2	2	4	0	0	2	4
	LKW	2	5	3	1	1	0	0	4	4	1	0	2
08:45 - 09:00	PKW	13	30	25	13	5	2	5	17	6	3	5	14
	KRAD	1	0	0	0	0	0	0	0	0	0	0	0
	LIEFERWAGEN	1	0	1	1	1	0	0	6	1	2	3	7
	LKW	0	4	1	3	1	1	0	5	1	0	0	3
09:00 - 09:15	PKW	15	15	19	8	4	3	0	11	4	4	8	10
	KRAD	0	0	0	0	0	1	0	0	0	0	0	0
	LIEFERWAGEN	2	1	4	1	0	0	0	1	0	1	2	0
	LKW	3	4	2	3	0	0	0	4	1	1	0	1
09:15 - 09:30	PKW	16	13	16	13	4	4	3	35	8	3	4	10
	KRAD	0	0	1	0	0	0	0	0	0	0	1	0
	LIEFERWAGEN	2	2	3	6	1	0	3	4	0	0	2	2
	LKW	2	4	4	2	1	0	1	2	0	2	0	2
09:30 - 09:45	PKW	9	17	21	10	4	1	3	22	7	3	5	16
	KRAD	0	0	1	1	0	0	0	0	0	0	0	0
	LIEFERWAGEN	2	1	0	1	1	0	1	2	0	3	0	1
	LKW	0	2	0	3	0	0	0	6	0	1	0	0
09:45 - 10:00	PKW	24	18	22	12	2	3	0	23	3	2	7	19
	KRAD	0	0	0	0	0	1	0	1	0	0	0	0
	LIEFERWAGEN	1	3	8	3	1	1	0	3	4	1	1	3
	LKW	2	10	3	4	0	0	1	3	1	0	0	0

Intervall	Fz-Arten	Wettener Straße			Gewerbering			Wettener Straße			Hoogeweg		
		LA	GA	RA	LE	GE	RE	LA	GE	RA	LE	GE	RE
		1	2	3	4	5	6	7	8	9	10	11	12
15:00 - 15:15	PKW	21	24	21	27	7	3	2	34	8	6	2	19
	KRAD	0	0	0	0	0	1	0	2	0	0	0	0
	LIEFERWAGEN	3	2	3	1	1	1	1	3	1	3	3	4
	LKW	3	11	1	4	0	0	0	7	2	0	0	1
15:15 - 15:30	PKW	14	29	26	22	11	5	1	34	10	6	8	19
	KRAD	0	0	1	0	0	0	0	0	0	0	0	0
	LIEFERWAGEN	5	1	3	5	2	1	2	5	1	0	2	2
	LKW	1	9	2	1	0	0	0	5	1	0	0	1
15:30 - 15:45	PKW	25	21	31	24	13	3	6	33	9	4	5	17
	KRAD	0	0	0	0	0	0	0	2	1	1	0	0
	LIEFERWAGEN	3	1	4	2	4	0	0	4	5	0	2	1
	LKW	2	4	1	0	1	0	0	9	0	1	0	1
15:45 - 16:00	PKW	28	23	19	45	8	7	7	32	11	8	8	34
	KRAD	0	1	0	0	0	1	0	2	0	0	0	0
	LIEFERWAGEN	7	3	2	2	1	1	0	4	2	1	3	5
	LKW	1	4	6	2	0	0	0	3	0	0	1	1
16:00 - 16:15	PKW	23	21	20	40	14	11	5	30	5	4	6	37
	KRAD	0	1	0	1	1	0	1	2	0	0	0	0
	LIEFERWAGEN	8	8	6	2	1	1	1	5	1	2	3	4
	LKW	0	4	3	2	0	0	0	5	0	0	2	1
16:15 - 16:30	PKW	34	29	15	39	8	6	10	35	9	14	7	22
	KRAD	0	0	0	1	0	0	0	0	0	0	0	0
	LIEFERWAGEN	6	5	6	6	3	0	1	3	5	2	1	5
	LKW	2	4	3	0	0	0	0	5	1	1	1	0
16:30 - 16:45	PKW	27	26	20	25	19	8	4	38	12	11	7	35
	KRAD	3	1	1	2	0	0	0	0	0	1	0	0
	LIEFERWAGEN	6	0	3	3	4	0	2	1	0	1	4	5
	LKW	2	3	0	1	0	0	0	3	1	1	0	0
16:45 - 17:00	PKW	31	25	28	33	16	13	2	26	13	7	6	32
	KRAD	0	0	0	0	2	1	0	0	0	0	0	1
	LIEFERWAGEN	7	7	4	2	1	0	0	6	1	0	3	4
	LKW	0	2	2	1	0	0	0	2	0	0	0	0
17:00 - 17:15	PKW	34	25	26	49	23	8	3	35	4	10	2	36
	KRAD	0	0	0	1	1	0	0	0	0	0	0	2
	LIEFERWAGEN	6	4	0	7	1	3	0	3	1	1	2	1
	LKW	0	3	3	1	0	0	1	0	0	1	1	1
17:15 - 17:30	PKW	34	26	20	34	11	2	4	21	10	5	7	20
	KRAD	2	1	0	1	0	0	0	0	0	0	0	0
	LIEFERWAGEN	4	1	6	7	2	1	1	4	1	1	2	3
	LKW m.A.	1	6	0	0	0	0	0	3	0	0	0	0
17:30 - 17:45	PKW	32	26	14	26	14	9	5	31	8	8	8	23
	KRAD	0	1	0	0	0	0	0	0	0	0	0	0
	LIEFERWAGEN	1	0	2	2	0	1	0	2	0	1	0	2
	LKW	0	1	0	0	0	0	0	5	1	1	0	1
17:45 - 18:00	PKW	42	28	20	22	12	7	6	12	4	5	5	21
	KRAD	0	0	1	0	0	0	0	1	1	0	0	0
	LIEFERWAGEN	2	4	0	0	0	0	0	1	0	0	0	0
	LKW	0	1	0	0	0	0	0	3	1	0	0	1
18:00 - 18:15	PKW	19	31	13	36	9	1	2	34	6	6	8	15
	KRAD	0	0	0	1	0	0	0	2	0	0	0	0
	LIEFERWAGEN	0	1	2	1	1	0	1	2	0	1	0	1
	LKW	1	0	0	0	0	0	0	1	0	0	0	0
18:15 - 18:30	PKW	15	17	14	19	8	1	2	26	12	5	2	11
	KRAD	0	0	0	0	0	0	0	0	0	0	0	1
	LIEFERWAGEN	1	0	0	0	0	0	0	0	0	1	0	1
	LKW	0	3	0	0	0	0	0	2	1	0	0	0
18:30 - 18:45	PKW	23	21	14	16	4	2	1	19	4	3	4	18
	KRAD	0	1	0	0	0	0	0	0	0	0	0	1
	LIEFERWAGEN	2	0	0	3	0	0	1	2	2	0	0	2
	LKW	0	2	0	0	0	0	0	1	1	0	0	0
18:45 - 19:00	PKW	21	23	9	13	4	4	0	25	6	6	3	11
	KRAD	0	0	0	0	0	0	0	0	0	0	0	0
	LIEFERWAGEN	1	1	0	1	1	0	0	2	0	0	0	0
	LKW	0	1	0	0	0	0	0	2	0	0	1	0

Knotenpunkt 1

Wettener Straße/ Gewerbering/ Hoogeweg

Intervall	Fz-Arten	Wettener Straße			Gewerbering			Wettener Straße			Hoogeweg		
		LA	GA	RA	LE	GE	RE	LA	GE	RA	LE	GE	RE
		1	2	3	4	5	6	7	8	9	10	11	12
Hochrechnung DTV													
Summe Kfz/4h (6-10)		330	402	385	188	74	38	67	417	125	117	144	258
Summe Pkw/4h (6-10)		278	299	318	103	39	24	44	325	92	87	120	193
Summe Lkw/4h (6-10)		52	103	67	85	35	14	23	92	33	30	24	65
Summe Kfz/4h (15-19)		503	497	375	533	208	102	72	579	162	129	119	423
Summe Pkw/4h (15-19)		428	401	313	477	185	93	61	476	133	110	88	375
Summe Lkw/4h (15-19)		74	90	62	56	23	9	11	100	29	19	31	48
DTV 24 Stunden		1	2	3	4	5	6	7	8	9	10	11	12
Morgens Kfz	21%	1542	1878	1799	878	346	178	313	1948	584	547	673	1205
Morgens Lkw	30%	173	342	223	282	116	47	76	306	110	100	80	216
Nachmittags Kfz	33%	1504	1486	1121	1593	622	305	215	1731	484	386	356	1265
Nachmittags Lkw	27%	279	339	234	211	87	34	41	377	109	72	117	181
Mittelwert aus mo und na		1523	1682	1460	1236	484	241	264	1840	534	466	514	1235
Lkw-Anteil mit Lieferverkehr		226	341	228	247	102	40	59	341	109	86	98	198
Lkw-Anteil mit Lieferverkehr in %		15%	20%	16%	20%	21%	17%	22%	19%	20%	18%	19%	16%

davon mo	PKW	274	293	310	101	39	22	44	321	91	87	118	192
	KRAD	4	6	8	2	0	2	0	4	1	0	2	1
	LIEFERWAGEN	32	49	40	44	28	9	18	56	20	18	20	43
	LKW	20	54	27	41	7	5	5	36	13	12	4	22

davon na	PKW	423	395	310	470	181	90	60	465	131	108	88	370
	KRAD	5	6	3	7	4	3	1	11	2	2	0	5
	LIEFERWAGEN	62	38	41	44	22	9	10	47	20	14	25	40
	LKW	12	52	21	12	1	0	1	53	9	5	6	8

Graphische Darstellung der DTV-Werte (Mittelwert aus mo und na):

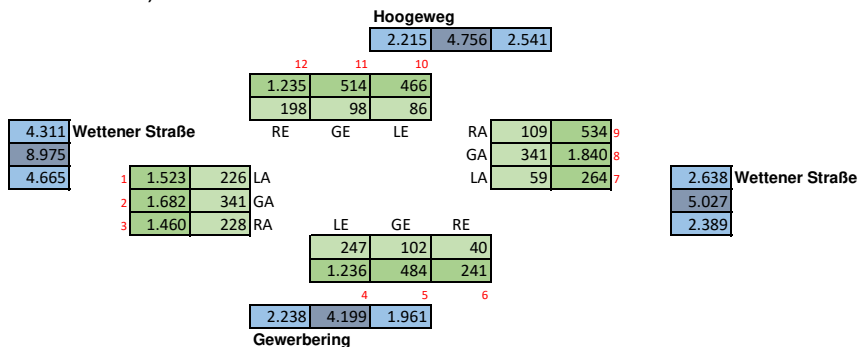
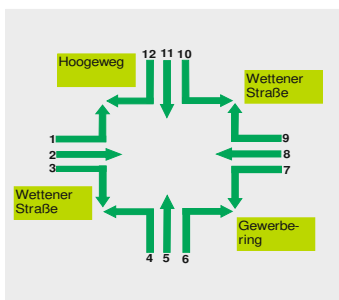

- Legende**
- DTV in Kfz/24h
 - Lkw in Kfz/24h
 - Gesamt DTV in beiden Richtungen
 - richtungsbezogener DTV

Graphische Darstellung der Spitzenstundenwerte morgens (7:00 - 8:00)

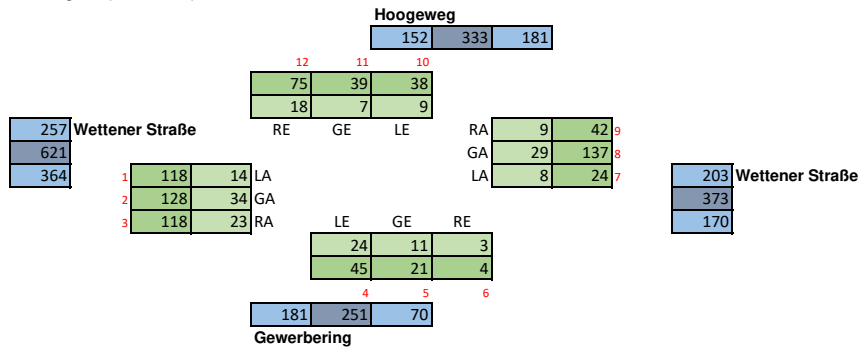
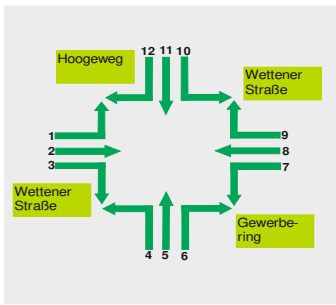

Graphische Darstellung der Spitzenstundenwerte nachmittags (16:00 - 17:00)

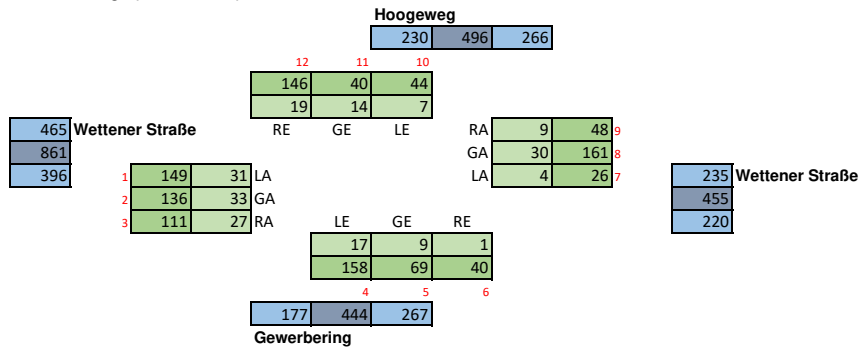

- Legende**
- Kfz/Spitzenstunde
 - Lkw/Spitzenstunde (inklusive Lieferverkehr)
 - Kfz/Spitzenstunde gesamt
 - Kfz/Spitzenstunde richtungsbezogen

Knotenpunkt 2

Köln Str. B9/Wettener Str./Feldstraße

September 2019

2 mal 4 Stunden-Zählung

Datum der Zählung: Do. 17.09.2019

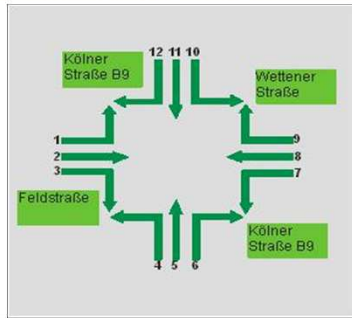

Intervall	Fz-Arten	Feldstraße			Köln Str.			Wettener Straße			Köln Str.		
		LA	GA	RA	LE	GE	RE	LA	GE	RA	LE	GE	RE
		1	2	3	4	5	6	7	8	9	10	11	12
06:00 - 06:15	PKW	0	9	7	9	34	6	1	9	4	10	53	3
	KRAD	0	0	0	0	0	0	1	0	0	1	0	0
	LIEFERWAGEN	1	1	2	2	0	2	1	3	1	1	3	0
	LKW	0	1	1	0	4	1	4	0	0	0	8	0
06:15 - 06:30	PKW	1	1	8	10	44	12	8	1	9	5	59	3
	KRAD	0	1	0	0	0	0	0	1	0	1	0	0
	LIEFERWAGEN	3	2	1	1	4	0	3	2	0	3	0	3
	LKW	0	1	3	1	1	0	2	1	1	0	11	2
06:30 - 06:45	PKW	2	14	3	6	48	23	4	10	7	17	100	7
	KRAD	0	0	0	0	0	0	1	0	0	0	0	0
	LIEFERWAGEN	1	6	4	2	1	2	4	0	1	2	7	0
	LKW	1	0	3	0	10	1	2	0	1	2	7	1
06:45 - 07:00	PKW	1	14	6	12	53	32	13	8	8	16	32	0
	KRAD	0	2	0	0	0	0	0	0	0	0	0	0
	LIEFERWAGEN	0	0	1	1	9	4	3	2	1	0	13	3
	LKW	0	0	0	0	8	0	1	0	6	2	14	0
07:00 - 07:15	PKW	3	11	15	11	74	25	7	15	7	25	71	3
	KRAD	0	1	0	0	0	1	0	0	0	1	0	0
	LIEFERWAGEN	2	3	3	1	2	3	3	1	4	5	16	2
	LKW	0	1	0	0	7	0	3	0	3	0	20	2
07:15 - 07:30	PKW	1	8	10	13	91	33	15	12	13	19	76	7
	KRAD	0	0	0	0	1	0	0	0	0	0	0	0
	LIEFERWAGEN	0	2	2	2	8	6	5	2	4	4	14	1
	LKW	0	1	1	1	10	3	4	2	1	4	7	0
07:30 - 07:45	PKW	3	16	15	23	57	33	16	22	22	17	104	6
	KRAD	0	1	0	1	0	0	0	3	0	3	2	1
	LIEFERWAGEN	1	3	5	4	8	3	8	3	3	0	11	4
	LKW	0	1	0	0	8	8	1	0	1	5	21	1
07:45 - 08:00	PKW	3	17	14	22	65	54	13	23	18	28	84	5
	KRAD	0	0	0	0	0	0	0	0	0	0	0	0
	LIEFERWAGEN	2	2	4	1	12	1	5	5	8	11	18	3
	LKW	1	2	1	0	14	3	3	0	2	2	18	2
08:00 - 08:15	PKW	5	17	13	15	46	18	16	6	15	25	72	4
	KRAD	0	0	0	0	0	0	0	0	0	0	0	0
	LIEFERWAGEN	1	6	5	2	13	2	2	0	3	0	12	6
	LKW	0	0	1	0	7	4	1	0	3	4	21	0
08:15 - 08:30	PKW	6	10	4	9	40	23	10	19	13	18	79	7
	KRAD	0	2	0	0	0	0	0	0	0	0	1	0
	LIEFERWAGEN	1	5	4	3	9	2	4	3	3	2	14	3
	LKW	0	0	0	0	18	2	5	1	5	4	17	0
08:30 - 08:45	PKW	4	15	12	9	46	19	11	12	14	14	58	4
	KRAD	0	0	0	0	1	1	0	0	0	0	0	0
	LIEFERWAGEN	2	1	4	1	5	2	5	5	5	4	3	2
	LKW	0	1	0	0	16	6	5	1	1	3	14	0
08:45 - 09:00	PKW	7	13	12	9	40	24	17	14	13	31	63	4
	KRAD	0	1	0	0	0	0	0	0	0	0	0	0
	LIEFERWAGEN	2	0	1	1	12	1	7	3	4	3	8	1
	LKW	0	0	0	0	11	3	9	1	1	2	14	0
09:00 - 09:15	PKW	2	17	8	18	42	17	7	11	11	15	40	8
	KRAD	0	0	0	0	0	0	0	0	0	0	0	0
	LIEFERWAGEN	1	1	4	0	9	3	0	0	2	3	3	1
	LKW	1	0	0	1	17	5	7	0	1	4	13	0
09:15 - 09:30	PKW	5	18	14	12	26	15	12	25	21	12	49	5
	KRAD	0	1	0	0	0	0	0	0	0	0	0	0
	LIEFERWAGEN	1	0	0	0	2	5	5	4	3	2	6	1
	LKW	2	1	0	0	17	4	3	0	3	5	14	0
09:30 - 09:45	PKW	7	15	5	10	51	13	14	18	16	19	32	11
	KRAD	0	0	0	0	0	1	0	0	1	0	2	0
	LIEFERWAGEN	0	2	3	1	7	1	0	2	2	0	9	0
	LKW	0	0	2	2	16	2	2	1	6	0	17	0
09:45 - 10:00	PKW	4	22	13	18	37	26	13	17	24	16	52	11
	KRAD	0	0	0	0	0	0	0	0	1	0	0	0
	LIEFERWAGEN	3	4	0	0	8	6	3	6	0	2	7	1
	LKW	2	1	0	1	8	10	5	0	2	4	10	0

Intervall	Fz-Arten	Feldstraße			Kölnener Straße			Wettener Straße			Kölnener Straße		
		LA	GA	RA	LE	GE	RE	LA	GE	RA	LE	GE	RE
		1	2	3	4	5	6	7	8	9	10	11	12
15:00 - 15:15	PKW	6	16	17	12	75	26	30	19	31	27	53	7
	KRAD	0	0	0	0	0	0	0	2	0	0	2	0
	LIEFERWAGEN	1	5	2	2	11	6	0	6	2	1	11	1
	LKW	0	0	2	0	11	10	9	1	2	4	9	0
15:15 - 15:30	PKW	7	20	20	10	59	24	25	24	26	25	53	9
	KRAD	0	1	0	0	1	0	0	0	0	0	1	0
	LIEFERWAGEN	1	2	1	2	18	7	3	2	7	0	12	0
	LKW	0	1	1	0	5	10	5	0	2	1	11	0
15:30 - 15:45	PKW	7	30	26	16	64	29	24	23	27	18	45	9
	KRAD	0	0	0	0	2	0	1	2	0	0	0	0
	LIEFERWAGEN	0	1	1	0	14	7	0	2	5	0	10	1
	LKW	0	0	1	0	16	7	7	0	3	0	4	1
15:45 - 16:00	PKW	10	25	26	17	82	26	41	34	36	19	66	1
	KRAD	0	1	0	0	0	0	0	1	0	0	0	0
	LIEFERWAGEN	1	2	2	3	15	5	3	3	5	5	10	0
	LKW	0	0	0	1	18	7	4	0	2	4	9	0
16:00 - 16:15	PKW	4	18	25	15	65	24	37	30	40	22	50	13
	KRAD	0	1	1	0	1	0	0	3	0	0	0	0
	LIEFERWAGEN	0	3	3	5	6	11	5	2	4	8	8	1
	LKW	0	0	0	0	19	4	5	0	3	3	10	1
16:15 - 16:30	PKW	10	28	29	11	87	26	34	30	32	24	67	18
	KRAD	0	0	0	0	1	0	0	0	1	0	0	0
	LIEFERWAGEN	1	5	1	5	15	8	7	4	3	4	11	2
	LKW	0	2	1	0	19	4	4	0	1	3	9	2
16:30 - 16:45	PKW	16	31	19	32	63	22	30	37	31	20	83	13
	KRAD	0	1	0	0	1	2	1	0	1	2	0	0
	LIEFERWAGEN	0	1	4	2	10	5	4	1	4	3	16	3
	LKW	0	0	0	1	6	4	3	1	0	1	4	0
16:45 - 17:00	PKW	9	35	38	23	85	26	37	25	29	23	76	15
	KRAD	0	0	0	0	2	0	0	1	0	0	0	0
	LIEFERWAGEN	0	5	1	2	14	7	3	3	6	6	7	3
	LKW	0	1	0	0	9	2	3	0	0	1	5	0
17:00 - 17:15	PKW	7	24	43	21	61	40	45	32	43	21	78	8
	KRAD	1	0	0	0	0	0	0	3	0	0	1	0
	LIEFERWAGEN	1	0	0	2	10	11	6	2	3	4	9	1
	LKW	0	1	0	0	10	3	1	1	0	2	5	0
17:15 - 17:30	PKW	8	24	23	15	84	33	29	20	26	23	53	17
	KRAD	0	2	0	1	0	1	0	1	0	0	4	0
	LIEFERWAGEN	1	2	5	3	10	3	10	0	4	6	6	0
	LKW m.A.	0	1	0	0	1	6	2	0	1	0	6	0
17:30 - 17:45	PKW	7	25	29	17	82	26	32	24	24	21	75	12
	KRAD	0	1	0	0	0	0	0	0	0	0	0	0
	LIEFERWAGEN	0	1	1	1	6	1	1	5	0	1	12	1
	LKW	0	0	0	0	5	1	5	0	1	0	4	1
17:45 - 18:00	PKW	8	27	26	9	62	32	21	18	16	31	66	3
	KRAD	0	0	0	0	1	0	0	1	0	1	0	0
	LIEFERWAGEN	1	3	3	1	7	0	0	0	1	3	5	0
	LKW	0	0	0	0	6	0	3	0	1	1	5	0
18:00 - 18:15	PKW	11	25	22	15	75	14	23	24	38	24	48	13
	KRAD	0	0	0	0	1	0	0	1	2	0	0	0
	LIEFERWAGEN	1	0	2	0	4	2	0	2	2	1	5	0
	LKW	0	0	0	1	4	1	1	0	0	0	3	0
18:15 - 18:30	PKW	8	16	25	15	73	15	22	20	14	15	56	13
	KRAD	0	0	1	0	0	0	0	1	0	0	0	0
	LIEFERWAGEN	0	1	1	0	12	0	0	1	0	0	7	1
	LKW	0	0	0	0	4	1	1	0	1	2	6	0
18:30 - 18:45	PKW	13	25	22	19	60	22	12	22	19	11	62	15
	KRAD	0	1	0	0	0	0	0	1	0	0	1	0
	LIEFERWAGEN	0	1	0	2	2	2	4	0	3	2	3	0
	LKW	0	0	0	0	3	0	1	0	0	2	2	0
18:45 - 19:00	PKW	16	17	13	15	35	15	12	21	16	21	56	6
	KRAD	0	0	0	1	0	0	0	0	0	0	0	0
	LIEFERWAGEN	0	1	0	1	2	1	0	1	2	0	8	0
	LKW	0	0	0	0	9	0	2	0	0	1	0	0

Knotenpunkt 2

Köln Str. B9/Wettener Str./Feldstraße

Intervall	Fz-Arten	Feldstraße			Köln Str. B9			Wettener Straße			Köln Str. B9		
		LA	GA	RA	LE	GE	RE	LA	GE	RA	LE	GE	RE
		1	2	3	4	5	6	7	8	9	10	11	12
Hochrechnung DTV													
Summe Kfz/4h (6-10)		82	274	214	235	1.077	471	294	274	298	376	1.399	128
Summe Pkw/4h (6-10)		54	226	159	207	796	376	179	226	217	293	1.029	89
Summe Lkw/4h (6-10)		28	48	55	28	281	95	115	48	81	83	370	39
Summe Kfz/4h (15-19)		156	433	437	298	1.423	539	558	457	520	417	1.228	191
Summe Pkw/4h (15-19)		148	394	405	264	1.122	403	456	420	452	348	996	172
Summe Lkw/4h (15-19)		8	38	32	34	300	130		37	67	69	226	19
DTV 24 Stunden		1	2	3	4	5	6	7	8	9	10	11	12
Morgens Kfz	21%	383	1280	1000	1098	5032	2201	1374	1280	1392	1757	6536	598
Morgens Lkw	30%	93	159	183	93	934	316	382	159	269	276	1229	130
Nachmittags Kfz	33%	466	1295	1306	891	4254	1611	1668	1366	1555	1247	3671	571
Nachmittags Lkw	27%	30	143	121	128	1131	490	377	140	253	260	852	72
Mittelwert aus mo und na		425	1287	1153	994	4643	1906	1521	1323	1473	1502	5104	585
Lkw-Anteil mit Lieferverkehr		62	151	152	111	1032	403	380	149	261	268	1041	101
Lkw-Anteil mit Lieferverkehr in %		15%	12%	13%	11%	22%	21%	25%	11%	18%	18%	20%	17%
davon mo	PKW	54	217	159	206	794	373	177	222	215	287	1.024	88
	KRAD	0	9	0	1	2	3	2	4	2	6	5	1
	LIEFERWAGEN	21	38	43	22	109	43	58	41	44	42	144	31
	LKW	7	10	12	6	172	52	57	7	37	41	226	8
davon	PKW	147	386	403	262	1.112	400	454	403	448	345	987	172
	KRAD	1	8	2	2	10	3	2	17	4	3	9	0
	LIEFERWAGEN	8	33	27	31	156	76	46	34	51	44	140	14
	LKW	0	5	5	3	144	54	54	3	16	25	86	5

Graphische Darstellung der DTV-Werte (Mittelwert aus mo und na):

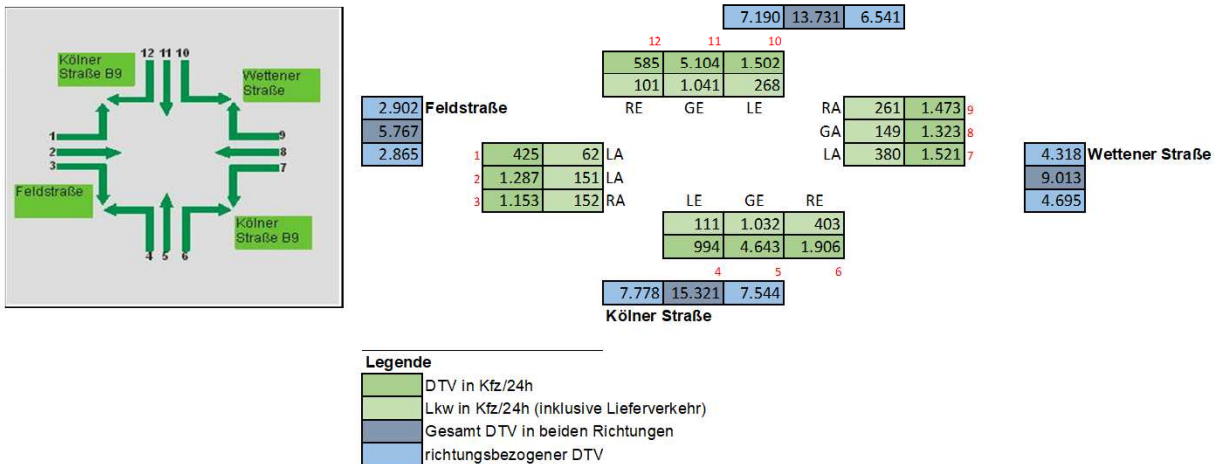

Graphische Darstellung der Spitzenstundenwerte morgens (7:00 - 8:00)

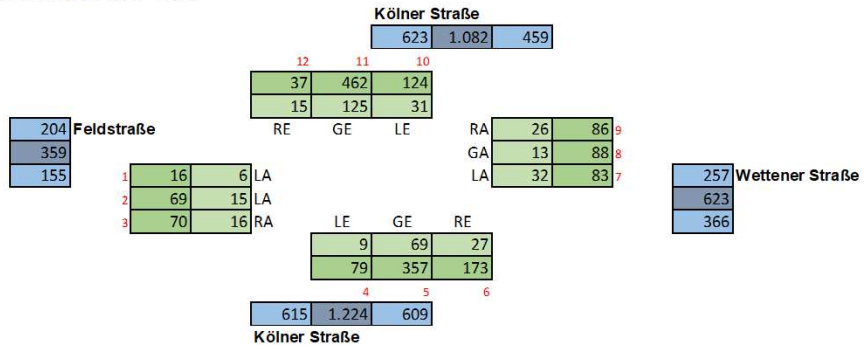
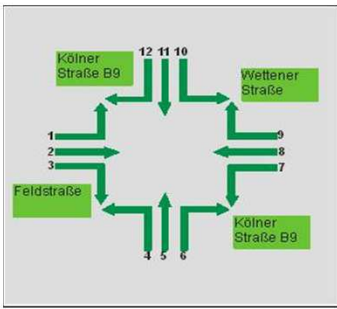

Graphische Darstellung der Spitzenstundenwerte nachmittags (16:00 - 17:00)

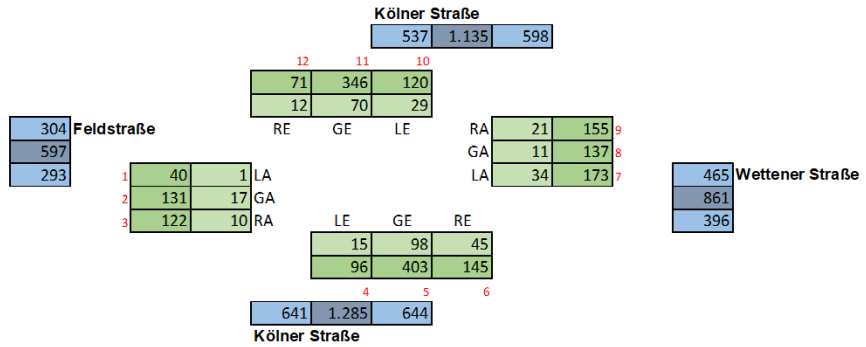

- Legende**
- Kfz/Spitzenstunde
 - Lkw/Spitzenstunde (inklusive Lieferverkehr)
 - Kfz/Spitzenstunde gesamt
 - Kfz/Spitzenstunde richtungsbezogen

Knotenpunkt 3

Köln Str. B9/Wellener Landstraße L491/Mühlenhoeksweg

September 2019

2 mal 4 Stunden-Zählung

Datum der Zählung: Do. 17.09.2019

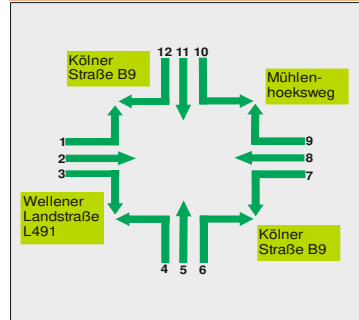

Intervall	Fz-Arten	Wellener Landstraße			Köln Str. B9			Mühlenhoeksweg			Köln Str. B9		
		LA	GA	RA	LE	GE	RE	LA	GE	RA	LE	GE	RE
		1	2	3	4	5	6	7	8	9	10	11	12
06:00 - 06:15	PKW	16	0	5	1	33	0	0	0	0	0	54	7
	KRAD	0	0	0	0	0	0	0	0	0	0	0	0
	LIEFERWAGEN	1	0	0	0	3	0	0	0	0	0	4	2
	LKW	3	0	0	0	2	0	0	0	0	0	11	2
06:15 - 06:30	PKW	22	0	3	3	44	0	0	0	0	0	65	10
	KRAD	0	0	0	0	0	0	0	0	0	0	0	0
	LIEFERWAGEN	2	0	0	0	3	0	0	0	0	0	3	1
	LKW	0	0	2	0	2	0	0	0	0	0	11	5
06:30 - 06:45	PKW	21	0	11	6	55	0	0	1	1	0	85	22
	KRAD	0	0	0	0	0	0	0	0	0	0	1	0
	LIEFERWAGEN	1	0	2	1	4	0	0	0	0	0	14	1
	LKW	1	0	0	0	10	0	0	0	0	0	9	3
06:45 - 07:00	PKW	34	0	6	4	63	0	0	0	0	1	39	11
	KRAD	0	0	0	0	0	0	0	0	0	0	0	0
	LIEFERWAGEN	4	0	2	1	10	0	0	0	0	0	16	1
	LKW	2	0	0	1	6	0	0	0	0	0	15	0
07:00 - 07:15	PKW	36	0	7	9	74	0	0	0	0	0	75	18
	KRAD	1	0	0	0	0	0	0	0	0	0	0	0
	LIEFERWAGEN	2	0	3	1	4	0	0	0	0	0	19	3
	LKW	1	0	1	0	6	0	0	0	0	0	20	3
07:15 - 07:30	PKW	44	0	12	10	93	0	0	1	0	0	73	28
	KRAD	0	0	0	0	1	0	0	0	0	0	0	0
	LIEFERWAGEN	6	0	1	1	10	0	0	0	0	0	19	2
	LKW	2	0	0	0	12	0	0	0	0	0	10	1
07:30 - 07:45	PKW	31	0	8	14	82	0	0	0	0	0	113	22
	KRAD	1	0	0	0	0	0	0	1	0	0	2	0
	LIEFERWAGEN	5	0	0	0	10	0	0	0	0	0	18	6
	LKW	4	0	0	1	12	0	0	0	0	0	16	6
07:45 - 08:00	PKW	50	0	12	4	91	0	0	1	0	0	74	37
	KRAD	0	0	0	0	0	0	0	0	0	0	0	0
	LIEFERWAGEN	5	0	2	1	9	0	0	0	0	0	20	7
	LKW	7	0	0	0	10	0	0	0	0	0	15	7
08:00 - 08:15	PKW	29	0	11	11	50	0	0	0	0	0	83	18
	KRAD	0	0	0	0	0	0	0	0	0	0	0	0
	LIEFERWAGEN	6	0	0	1	11	0	0	0	0	0	15	4
	LKW	2	0	1	1	9	0	0	0	0	0	16	7
08:15 - 08:30	PKW	13	1	2	5	59	1	0	0	0	0	78	15
	KRAD	0	0	0	0	0	0	0	0	0	0	1	0
	LIEFERWAGEN	3	0	0	0	11	0	0	0	0	0	18	4
	LKW	1	0	0	0	18	0	0	0	1	0	20	2
08:30 - 08:45	PKW	26	0	7	7	47	0	0	0	1	0	69	12
	KRAD	1	0	0	0	1	0	0	0	0	0	0	0
	LIEFERWAGEN	2	0	1	1	6	0	0	0	0	0	8	4
	LKW	4	0	0	0	18	0	0	0	0	0	15	4
08:45 - 09:00	PKW	21	1	4	3	50	0	1	0	2	1	70	21
	KRAD	0	0	0	0	0	0	0	0	0	0	0	0
	LIEFERWAGEN	8	0	1	0	6	0	0	0	0	0	8	8
	LKW	3	0	1	0	11	0	0	0	0	0	20	3
09:00 - 09:15	PKW	19	0	7	4	58	0	0	1	0	0	43	12
	KRAD	0	0	0	0	0	0	0	0	0	0	0	0
	LIEFERWAGEN	4	0	1	0	8	0	0	0	0	0	5	2
	LKW	3	0	2	0	20	0	0	0	0	0	15	5
09:15 - 09:30	PKW	10	0	5	3	43	0	0	1	0	1	52	22
	KRAD	0	0	0	0	0	0	0	0	0	0	0	0
	LIEFERWAGEN	1	0	1	1	6	0	0	0	0	0	6	5
	LKW	5	1	0	1	16	0	0	0	0	0	14	3
09:30 - 09:45	PKW	22	1	7	2	52	0	0	1	0	0	38	13
	KRAD	0	0	0	0	1	0	0	0	0	0	2	0
	LIEFERWAGEN	2	0	1	1	7	0	0	0	0	0	8	4
	LKW	8	0	2	2	12	0	0	0	0	0	18	3
09:45 - 10:00	PKW	18	0	3	5	63	0	0	0	0	0	54	24
	KRAD	0	0	0	0	0	0	0	0	0	0	0	0
	LIEFERWAGEN	3	1	0	1	11	0	0	1	0	0	6	4
	LKW	5	0	0	1	14	0	0	1	0	0	11	4

Intervall	Fz-Arten	Wellener Landstraße			Kölnener Straße			Mühlenhoeksberg			Kölnener Straße		
		LA	GA	RA	LE	GE	RE	LA	GE	RA	LE	GE	RE
		1	2	3	4	5	6	7	8	9	10	11	12
15:00 - 15:15	PKW	25	0	3	6	84	0	0	1	1	0	70	30
	KRAD	0	0	0	0	0	0	0	0	0	0	1	1
	LIEFERWAGEN	5	0	0	3	10	0	0	0	0	0	8	5
	LKW	8	0	0	1	14	0	0	0	0	0	14	6
15:15 - 15:30	PKW	16	1	8	14	77	0	0	0	1	0	66	33
	KRAD	0	0	0	0	1	0	0	0	0	0	1	0
	LIEFERWAGEN	7	0	2	1	20	0	0	0	0	0	10	6
	LKW	4	0	0	3	11	0	0	0	0	0	9	8
15:30 - 15:45	PKW	25	0	11	9	83	0	0	0	1	0	53	42
	KRAD	0	0	0	0	2	0	0	0	0	0	1	0
	LIEFERWAGEN	2	0	2	1	19	0	0	1	0	0	7	4
	LKW	5	0	3	2	18	0	0	0	0	0	10	2
15:45 - 16:00	PKW	28	1	12	6	96	0	0	1	1	1	91	41
	KRAD	0	0	0	0	0	0	0	0	0	0	0	0
	LIEFERWAGEN	5	1	1	2	18	0	0	0	0	0	11	4
	LKW	8	0	0	0	18	0	0	0	0	0	3	10
16:00 - 16:15	PKW	23	0	6	11	81	0	0	1	0	0	69	43
	KRAD	0	0	0	0	1	0	0	0	0	0	1	0
	LIEFERWAGEN	8	0	0	1	14	0	0	0	0	0	9	7
	LKW	6	0	1	1	18	0	0	0	0	0	10	6
16:15 - 16:30	PKW	22	1	12	15	102	0	0	2	0	1	75	54
	KRAD	0	0	0	0	1	0	0	0	0	0	0	0
	LIEFERWAGEN	6	1	1	0	22	0	0	0	0	0	14	5
	LKW	4	0	0	2	19	0	0	0	0	0	7	7
16:30 - 16:45	PKW	29	1	9	14	88	0	0	0	1	1	93	39
	KRAD	2	0	0	0	1	0	0	0	0	0	0	1
	LIEFERWAGEN	7	0	0	1	10	0	0	0	0	1	17	6
	LKW	2	0	1	1	9	0	0	0	0	0	6	1
16:45 - 17:00	PKW	30	2	11	6	104	1	0	0	0	2	106	43
	KRAD	0	0	0	0	2	0	0	0	0	0	0	0
	LIEFERWAGEN	9	0	0	1	14	0	0	1	0	0	6	5
	LKW	3	0	1	0	8	0	0	0	0	0	7	1
17:00 - 17:15	PKW	34	2	8	14	87	1	0	0	1	0	114	52
	KRAD	0	0	0	0	0	0	0	0	0	0	0	1
	LIEFERWAGEN	6	0	0	1	17	0	0	0	0	1	7	11
	LKW	3	0	0	0	10	0	0	0	0	0	2	4
17:15 - 17:30	PKW	26	0	11	23	106	0	0	0	0	0	69	36
	KRAD	1	0	0	0	1	0	0	0	0	0	3	1
	LIEFERWAGEN	5	0	3	1	11	0	0	0	0	0	15	6
	LKW m.A.	1	0	0	1	6	0	0	0	0	0	7	1
17:30 - 17:45	PKW	32	2	6	11	92	0	0	1	1	1	88	47
	KRAD	0	0	1	0	0	0	0	0	0	0	0	0
	LIEFERWAGEN	2	0	0	1	6	0	0	0	0	0	10	4
	LKW	1	0	0	1	5	0	0	0	0	0	6	3
17:45 - 18:00	PKW	28	4	13	15	75	0	0	2	1	1	78	35
	KRAD	0	0	0	0	1	0	0	0	0	0	0	0
	LIEFERWAGEN	1	0	0	0	7	0	0	0	0	0	5	3
	LKW	5	0	0	0	1	0	0	0	0	0	3	5
18:00 - 18:15	PKW	23	1	6	13	78	1	0	3	3	0	61	32
	KRAD	1	0	0	0	0	0	0	0	0	0	0	0
	LIEFERWAGEN	0	0	1	0	6	0	0	0	0	0	4	3
	LKW	1	0	0	0	5	0	0	0	0	0	3	1
18:15 - 18:30	PKW	16	1	3	10	87	0	0	0	0	0	78	25
	KRAD	0	0	0	0	0	0	0	0	0	0	0	1
	LIEFERWAGEN	1	0	1	1	11	0	0	1	0	1	6	1
	LKW	3	0	0	0	2	0	0	0	0	0	6	1
18:30 - 18:45	PKW	32	1	0	9	68	0	0	1	1	2	67	27
	KRAD	0	0	0	0	0	0	0	0	0	0	1	0
	LIEFERWAGEN	0	0	0	0	6	0	0	0	0	0	4	3
	LKW	0	0	0	1	3	0	0	0	0	0	2	1
18:45 - 19:00	PKW	14	0	5	12	51	0	0	2	0	1	51	29
	KRAD	0	0	0	0	1	0	0	0	0	0	0	0
	LIEFERWAGEN	3	0	0	0	1	0	0	0	0	0	8	0
	LKW	1	0	0	0	8	0	0	0	0	0	1	1

Knotenpunkt 3

Köln Str. B9/Wellener Landstraße L491/Mühlenhoeksweg

Intervall	Fz-Arten	Wellener Landstraße			Köln Str. B9			Mühlenhoeksweg			Köln Str. B9		
		LA	GA	RA	LE	GE	RE	LA	GE	RA	LE	GE	RE
		1	2	3	4	5	6	7	8	9	10	11	12
Hochrechnung DTV													
Summe Kfz/4h (6-10)		521	5	134	108	1.257	1	1	9	5	3	1.494	408
Summe Pkw/4h (6-10)		415	3	110	91	960	1	1	7	4	3	1.071	292
Summe Lkw/4h (6-10)		106	2	24	17	297	0	0	2	1	0	423	116
Summe Kfz/4h (15-19)		529	19	142	215	1.717	3	0	17	12	13	1.474	744
Summe Pkw/4h (15-19)		407	17	125	188	1.370	3	0	14	12	10	1.237	613
Summe Lkw/4h (15-19)		121	2	17	26	341	0	0	3	0	3	237	130
DTV 24 Stunden		1	2	3	4	5	6	7	8	9	10	11	12
Morgens Kfz	21%	2434	23	626	505	5873	5	5	42	23	14	6980	1906
Morgens Lkw	30%	352	7	80	56	987	0	0	7	3	0	1405	385
Nachmittags Kfz	33%	1582	57	425	643	5133	9	0	51	36	39	4407	2224
Nachmittags Lkw	27%	456	8	64	98	1286	0	0	11	0	11	867	490
Mittelwert aus mo und na		2008	40	525	574	5503	7	2	46	30	26	5693	2065
Lkw-Anteil mit Lieferverkehr		404	7	72	77	1136	0	0	9	2	6	1136	438
Lkw-Anteil mit Lieferverkehr in %		20%	18%	14%	13%	21%	0%	0%	19%	6%	21%	20%	21%
davon mo	PKW	412	3	110	91	957	1	1	6	4	3	1.065	292
	KRAD	3	0	0	0	3	0	0	1	0	0	6	0
	LIEFERWAGEN	55	1	15	10	119	0	0	1	0	0	187	58
	LKW	51	1	9	7	178	0	0	1	1	0	236	58
davon	PKW	403	17	124	188	1.359	3	0	14	12	10	1.229	608
	KRAD	4	0	1	0	11	0	0	0	0	0	8	5
	LIEFERWAGEN	67	2	11	14	192	0	0	3	0	3	141	73
	LKW	54	0	6	12	149	0	0	0	0	0	89	57

Graphische Darstellung der DTV-Werte (Mittelwert aus mo und na):

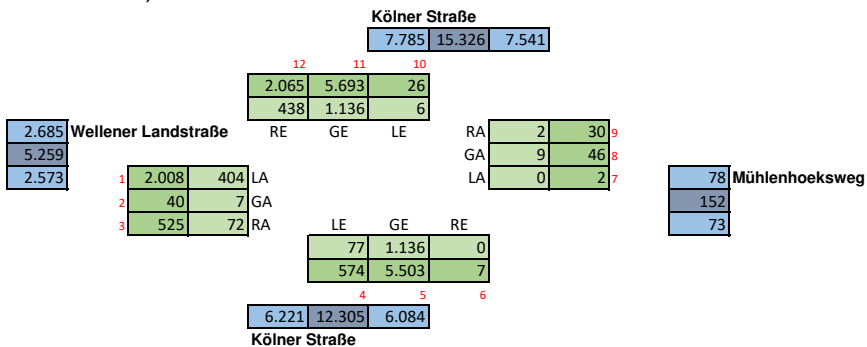
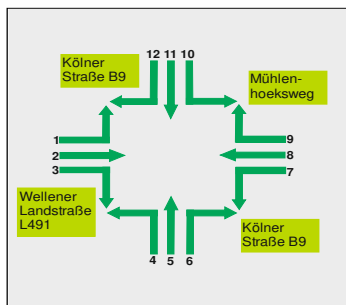

- Legende**
- DTV in Kfz/24h
 - Lkw in Kfz/24h (inklusive Lieferverkehr)
 - Gesamt DTV in beiden Richtungen
 - richtungsbezogener DTV

Graphische Darstellung der Spitzenstundenwerte morgens (7:00 - 8:00)

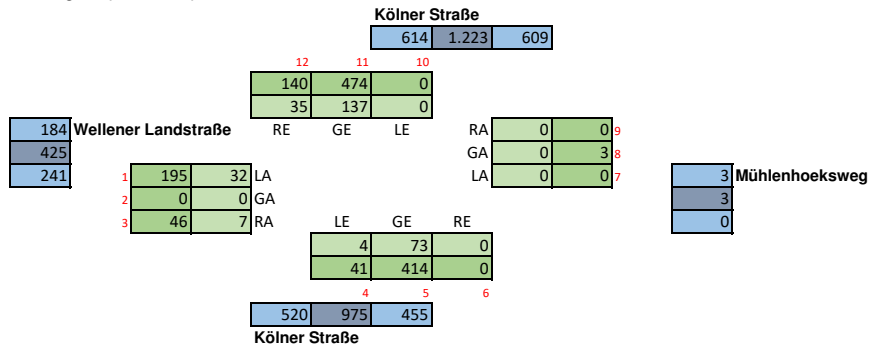
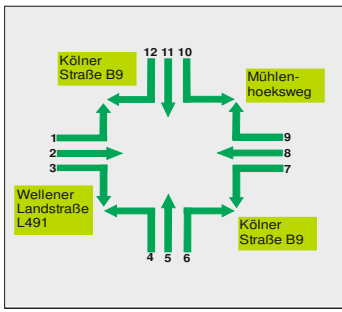

Graphische Darstellung der Spitzenstundenwerte nachmittags (17:00 - 18:00)

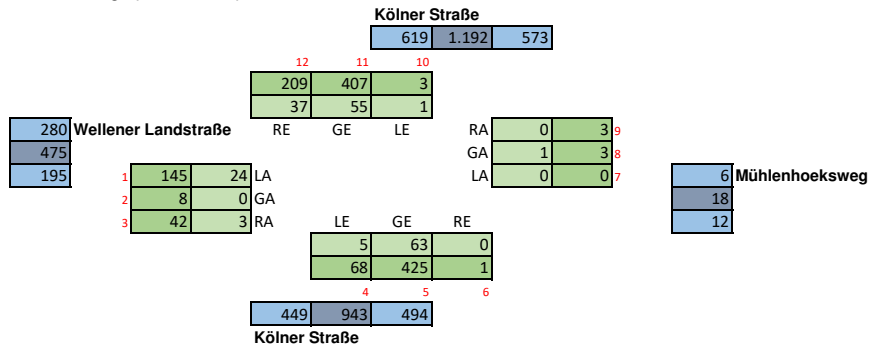

- Legende**
- Kfz/Spitzenstunde
 - Lkw/Spitzenstunde (inklusive Lieferverkehr)
 - Kfz/Spitzenstunde gesamt
 - Kfz/Spitzenstunde richtungsbezogen

Knotenpunkt 4

Rheinstraße/Kölnstraße B9/Klevert Straße B9

September 2019

2 mal 4 Stunden-Zählung

Datum der Zählung: Do. 19.09.2019

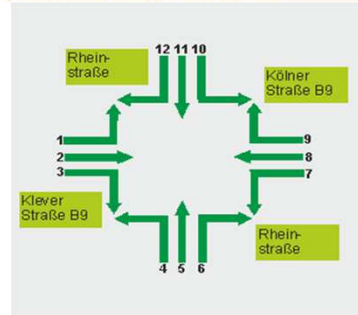

Intervall	Fz-Arten	Klevert Straße			Rheinstraße			Köln Straße			Rheinstraße		
		LA	GA	RA	LE	GE	RE	LA	GE	RA	LE	GE	RE
		1	2	3	4	5	6	7	8	9	10	11	12
06:00 - 06:15	PKW	15	40	5	4	16	1	0	22	8	19	17	5
	KRAD	0	0	0	0	0	0	0	0	1	0	0	0
	LIEFERWAGEN	2	6	2	1	4	0	0	4	4	1	2	4
	LKW	7	12	0	0	0	0	0	4	3	2	0	1
06:15 - 06:30	PKW	23	60	11	2	21	0	2	23	14	15	9	11
	KRAD	0	0	0	0	0	0	0	0	0	0	0	0
	LIEFERWAGEN	1	6	0	1	4	0	0	6	2	6	3	3
	LKW	2	15	2	2	0	0	0	2	2	2	1	0
06:30 - 06:45	PKW	28	73	11	8	22	0	1	41	14	27	18	10
	KRAD	0	0	0	0	0	0	0	1	0	0	0	0
	LIEFERWAGEN	3	6	1	0	9	1	0	8	3	3	4	3
	LKW	0	14	1	0	1	0	0	6	5	3	1	2
06:45 - 07:00	PKW	37	46	11	12	27	2	0	66	19	16	17	11
	KRAD	0	0	0	0	0	0	0	0	0	0	0	0
	LIEFERWAGEN	7	16	2	1	7	0	2	6	2	10	4	1
	LKW	2	12	0	1	0	0	1	8	2	7	0	1
07:00 - 07:15	PKW	27	70	18	11	21	0	0	53	17	27	26	19
	KRAD	0	0	0	0	0	0	0	1	0	1	2	0
	LIEFERWAGEN	1	18	1	0	1	0	0	6	5	2	2	8
	LKW	3	16	3	1	2	0	0	5	4	5	4	0
07:15 - 07:30	PKW	37	82	13	17	31	0	0	65	18	24	33	32
	KRAD	0	2	0	0	0	0	0	0	1	0	3	0
	LIEFERWAGEN	6	18	1	1	3	0	1	7	4	1	3	2
	LKW	1	9	1	0	0	1	1	4	2	3	1	2
07:30 - 07:45	PKW	57	108	21	9	25	1	1	63	26	16	44	29
	KRAD	0	4	0	0	0	0	0	0	0	0	1	0
	LIEFERWAGEN	4	19	2	1	5	0	0	13	3	3	3	7
	LKW	2	21	0	2	2	0	0	6	4	4	0	3
07:45 - 08:00	PKW	44	95	20	13	22	2	4	55	14	25	37	18
	KRAD	1	0	0	0	1	0	0	0	0	1	0	0
	LIEFERWAGEN	2	18	2	5	7	1	0	8	5	3	7	7
	LKW	1	16	2	1	1	0	0	9	4	7	1	3
08:00 - 08:15	PKW	33	79	17	17	23	2	5	49	20	18	46	21
	KRAD	0	0	0	0	0	0	0	0	0	0	0	0
	LIEFERWAGEN	6	10	1	2	5	0	1	16	8	7	7	4
	LKW	1	14	0	1	1	0	1	8	6	10	0	1
08:15 - 08:30	PKW	38	76	9	7	26	2	3	58	11	19	30	20
	KRAD	0	1	0	0	0	0	0	0	0	0	1	0
	LIEFERWAGEN	4	14	2	2	5	1	0	18	1	6	4	5
	LKW	0	13	0	1	0	1	0	11	9	7	1	0
08:30 - 08:45	PKW	20	61	13	14	27	0	4	38	13	19	43	24
	KRAD	0	1	0	0	1	0	0	1	0	0	0	0
	LIEFERWAGEN	2	8	0	2	3	0	0	14	2	5	2	3
	LKW	0	11	1	0	2	0	0	8	7	7	2	5
08:45 - 09:00	PKW	37	67	19	10	20	2	4	53	18	20	36	21
	KRAD	0	1	0	0	0	0	0	2	0	0	0	0
	LIEFERWAGEN	5	0	0	1	3	0	0	10	3	2	1	2
	LKW	2	14	0	1	0	0	1	5	4	6	3	1
09:00 - 09:15	PKW	30	48	25	14	21	2	4	39	10	17	42	31
	KRAD	0	0	0	0	0	0	0	0	0	0	0	1
	LIEFERWAGEN	1	10	3	0	2	0	0	11	0	3	5	2
	LKW	3	11	0	2	0	0	0	9	8	7	2	3
09:15 - 09:30	PKW	29	47	21	13	11	3	3	45	10	16	47	24
	KRAD	0	0	0	0	0	0	0	0	0	0	0	0
	LIEFERWAGEN	1	5	1	0	4	0	0	5	2	3	6	4
	LKW	0	13	0	1	0	0	1	11	7	2	3	1
09:30 - 09:45	PKW	27	39	14	12	19	2	12	50	8	23	37	25
	KRAD	0	2	0	0	1	0	0	1	0	0	1	0
	LIEFERWAGEN	2	6	3	0	1	0	0	9	3	1	5	2
	LKW	1	13	1	0	3	0	0	14	9	5	1	2
09:45 - 10:00	PKW	27	63	23	20	25	5	7	51	14	16	43	24
	KRAD	0	0	0	0	0	0	0	1	0	0	0	0
	LIEFERWAGEN	7	7	1	1	6	0	0	8	1	4	3	4
	LKW	2	10	0	1	0	0	0	10	6	3	0	0

Intervall	Fz-Arten	Klever Straße			Rheinstraße			Köiner Straße			Rheinstraße		
		LA	GA	RA	LE	GE	RE	LA	GE	RA	LE	GE	RE
		1	2	3	4	5	6	7	8	9	10	11	12
15:00 - 15:15	PKW	32	65	29	20	45	5	8	74	19	22	46	27
	KRAD	0	1	0	0	0	0	0	0	0	0	1	0
	LIEFERWAGEN	3	6	3	1	4	0	1	7	7	5	4	2
	LKW	3	10	1	0	1	0	1	3	7	5	0	0
15:15 - 15:30	PKW	35	74	18	22	30	1	5	85	21	10	35	34
	KRAD	0	1	0	0	0	0	0	2	0	1	1	0
	LIEFERWAGEN	4	4	1	4	4	0	1	15	1	6	6	4
	LKW	1	11	1	0	1	0	0	12	4	4	1	1
15:30 - 15:45	PKW	28	59	25	23	29	2	7	65	11	18	50	24
	KRAD	0	1	0	0	0	0	1	2	0	0	0	0
	LIEFERWAGEN	4	5	3	0	6	0	0	26	7	4	4	5
	LKW	1	8	0	0	1	0	0	10	5	2	0	3
15:45 - 16:00	PKW	46	60	26	28	37	5	7	95	16	14	40	38
	KRAD	0	1	0	1	5	0	0	0	0	0	1	0
	LIEFERWAGEN	4	9	2	1	5	0	2	13	5	5	2	1
	LKW	1	9	0	0	0	0	0	18	4	4	2	0
16:00 - 16:15	PKW	34	80	21	25	42	4	3	80	21	19	42	27
	KRAD	0	0	1	2	0	0	0	0	1	0	0	0
	LIEFERWAGEN	9	18	1	3	4	0	0	8	4	3	5	3
	LKW	1	9	0	0	2	0	0	7	8	4	1	1
16:15 - 16:30	PKW	42	85	25	31	43	3	9	73	24	15	49	33
	KRAD	0	0	0	1	0	0	0	2	1	0	0	0
	LIEFERWAGEN	4	12	0	4	6	0	1	13	2	1	8	1
	LKW	1	10	0	1	0	0	0	12	3	5	2	2
16:30 - 16:45	PKW	34	81	27	35	50	2	1	90	11	25	41	31
	KRAD	0	2	0	0	0	0	0	1	0	0	0	0
	LIEFERWAGEN	5	16	1	3	3	0	0	17	2	3	6	4
	LKW	1	4	0	1	1	0	0	11	4	2	0	1
16:45 - 17:00	PKW	35	86	19	37	47	5	7	85	29	16	49	42
	KRAD	0	0	0	0	0	0	0	3	0	0	1	0
	LIEFERWAGEN	8	12	0	3	3	0	0	11	2	2	4	5
	LKW	2	4	0	1	1	0	0	5	3	5	0	0
17:00 - 17:15	PKW	46	95	33	23	42	5	3	106	23	19	37	31
	KRAD	0	0	0	0	1	0	0	1	0	0	2	0
	LIEFERWAGEN	7	9	0	1	1	0	1	19	0	1	5	4
	LKW	0	4	0	1	2	0	0	5	4	2	0	3
17:15 - 17:30	PKW	54	72	21	30	44	0	7	92	31	22	45	33
	KRAD	0	2	0	0	0	0	0	0	0	2	0	0
	LIEFERWAGEN	4	10	2	4	3	0	0	11	5	1	6	3
	LKW m.A.	0	4	0	0	0	0	0	6	3	1	1	1
17:30 - 17:45	PKW	43	63	24	40	61	5	4	75	20	25	42	40
	KRAD	0	0	0	0	0	1	0	0	0	0	0	0
	LIEFERWAGEN	3	7	1	1	5	0	0	2	6	2	5	2
	LKW	0	2	0	1	1	0	0	4	0	4	0	0
17:45 - 18:00	PKW	51	82	30	23	41	2	4	79	22	17	56	29
	KRAD	0	0	0	0	0	0	0	0	0	0	1	1
	LIEFERWAGEN	3	5	3	2	3	1	0	6	5	2	3	3
	LKW	3	3	1	0	0	0	0	5	4	3	0	0
18:00 - 18:15	PKW	41	62	27	31	43	6	11	73	19	15	56	38
	KRAD	0	0	0	0	0	0	0	3	0	0	2	0
	LIEFERWAGEN	0	4	2	1	4	0	0	5	4	0	4	3
	LKW	0	3	0	0	0	0	0	3	2	2	0	0
18:15 - 18:30	PKW	39	65	24	23	31	5	5	85	19	15	46	33
	KRAD	0	0	0	1	0	0	0	0	0	0	0	0
	LIEFERWAGEN	2	3	1	1	2	0	0	8	3	4	0	0
	LKW	0	4	0	0	0	0	0	2	2	0	0	2
18:30 - 18:45	PKW	44	60	18	13	28	2	3	53	23	35	45	30
	KRAD	0	0	0	1	0	0	0	0	0	0	2	0
	LIEFERWAGEN	2	7	0	3	0	0	0	5	4	1	3	3
	LKW	0	1	0	0	1	0	0	2	0	3	1	1
18:45 - 19:00	PKW	22	49	14	15	48	4	1	54	34	13	31	21
	KRAD	1	0	0	0	0	0	0	0	0	2	0	0
	LIEFERWAGEN	0	2	0	0	3	1	0	4	2	1	2	1
	LKW	1	0	0	0	0	0	0	1	4	1	0	0

Knotenpunkt 4

Rheinstraße/Köln Straße B9/Klevert Straße B9

Intervall	Fz-Arten	Klevert Straße			Rheinstraße			Köln Straße			Rheinstraße		
		LA	GA	RA	LE	GE	RE	LA	GE	RA	LE	GE	RE
		1	2	3	4	5	6	7	8	9	10	11	12
Hochrechnung DTV													
Summe Kfz/4h (6-10)		591	1.446	284	215	441	29	59	1.047	366	459	614	412
Summe Pkw/4h (6-10)		510	1.065	251	183	360	24	50	778	236	319	533	326
Summe Lkw/4h (6-10)		81	381	33	32	81	5	9	269	130	140	81	86
Summe Kfz/4h (15-19)		704	1.361	405	462	734	59	93	1.554	461	393	796	571
Summe Pkw/4h (15-19)		627	1.146	382	425	667	57	86	1.278	345	305	721	512
Summe Lkw/4h (15-19)		77	211	23	37	67	2	7	270	113	87	74	58
DTV 24 Stunden		1	2	3	4	5	6	7	8	9	10	11	12
Morgens Kfz	21%	2761	6756	1327	1005	2060	135	276	4892	1710	2145	2869	1925
Morgens Lkw	30%	269	1266	110	106	269	17	30	894	432	465	269	286
Nachmittags Kfz	33%	2105	4069	1211	1381	2194	176	278	4646	1378	1175	2380	1707
Nachmittags Lkw	27%	290	796	87	140	253	8	26	1018	426	328	279	219
Mittelwert aus mo und na		2433	5412	1269	1193	2127	156	277	4769	1544	1660	2624	1816
Lkw-Anteil mit Lieferverkehr		280	1031	98	123	261	12	28	956	429	397	274	252
Lkw-Anteil mit Lieferverkehr in %		11%	19%	8%	10%	12%	8%	10%	20%	28%	24%	10%	14%
davon mo	PKW	509	1.054	251	183	357	24	50	771	234	317	525	325
	KRAD	1	11	0	0	3	0	0	7	2	2	8	1
	LIEFERWAGEN	54	167	22	18	69	3	4	149	48	60	61	61
	LKW	27	214	11	14	12	2	5	120	82	80	20	25
davon	PKW	626	1.138	381	419	661	56	85	1.264	343	300	710	511
	KRAD	1	8	1	6	6	1	1	14	2	5	11	1
	LIEFERWAGEN	62	129	20	32	56	2	6	170	59	41	67	44
	LKW	15	82	3	5	11	0	1	100	54	46	7	14

Graphische Darstellung der DTV-Werte (Mittelwert aus mo und na):

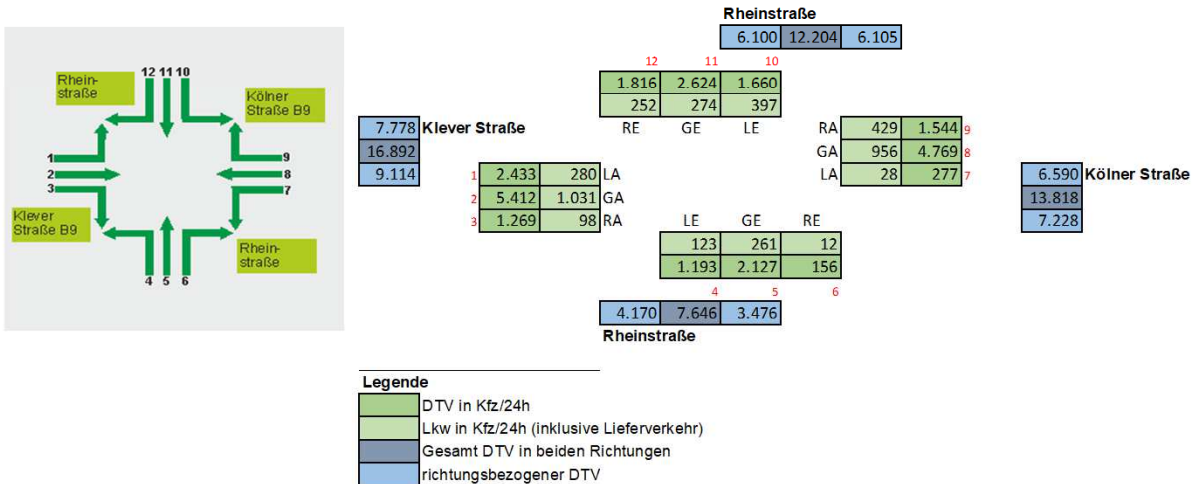

Graphische Darstellung der Spitzenstundenwerte morgens (7:00 - 8:00)

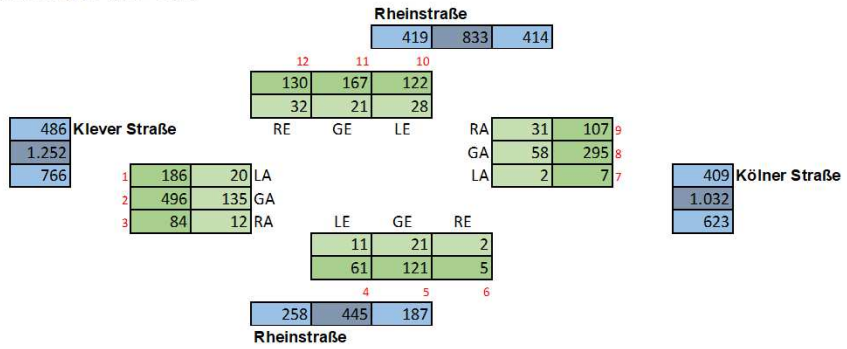
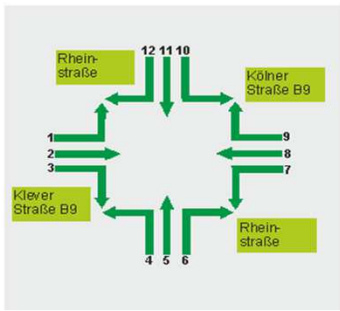

Graphische Darstellung der Spitzenstundenwerte nachmittags (17:00 - 18:00)

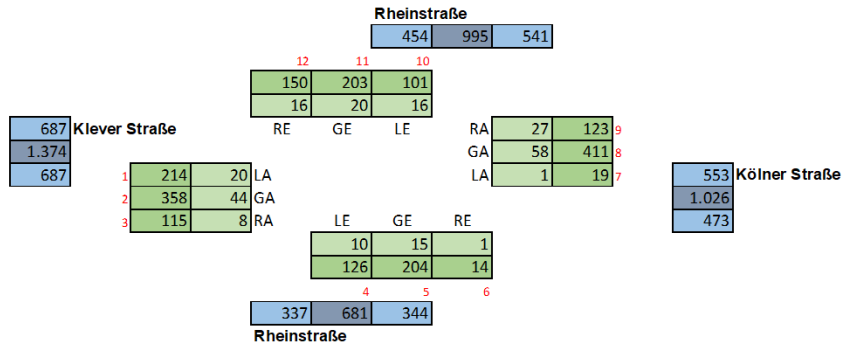

- Legende**
- Kfz/Spitzenstunde
 - Lkw/Spitzenstunde (inklusive Lieferverkehr)
 - Kfz/Spitzenstunde gesamt
 - Kfz/Spitzenstunde richtungsbezogen

Knotenpunkt 5

Wellener Landstraße L491/Südstraße

September 2019

2 mal 4 Stunden-Zählung

Datum der Zählung: Do. 17.09.2019

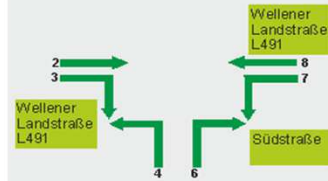

Intervall	Fz-Arten	Wellener Landstraße			Südstraße			Wellener Landstraße		
		GA	RA	LE	RE	LA	GE			
		2	3	4	6	7	8			
06:00 - 06:15	PKW	16	5	1	4	2	6			
	KRAD	0	0	0	0	0	0			
	LIEFERWAGEN	1	0	0	0	0	0			
	LKW	0	0	0	3	0	3			
06:15 - 06:30	PKW	23	1	3	3	5	9			
	KRAD	0	0	0	0	0	0			
	LIEFERWAGEN	2	0	0	0	0	1			
	LKW	2	0	1	0	1	4			
06:30 - 06:45	PKW	31	3	0	6	5	24			
	KRAD	0	0	0	0	0	0			
	LIEFERWAGEN	3	0	1	0	1	1			
	LKW	1	0	0	0	0	3			
06:45 - 07:00	PKW	23	6	2	11	7	9			
	KRAD	0	0	0	0	0	0			
	LIEFERWAGEN	6	0	2	0	0	2			
	LKW	2	1	1	0	0	1			
07:00 - 07:15	PKW	44	5	4	2	3	23			
	KRAD	1	0	0	0	0	0			
	LIEFERWAGEN	4	0	1	1	0	4			
	LKW	2	0	0	1	0	3			
07:15 - 07:30	PKW	47	8	6	6	9	33			
	KRAD	0	0	0	0	0	1			
	LIEFERWAGEN	4	1	1	3	1	2			
	LKW	0	0	0	1	2	0			
07:30 - 07:45	PKW	39	7	5	5	5	31			
	KRAD	1	0	0	0	0	0			
	LIEFERWAGEN	4	0	2	1	2	3			
	LKW	5	2	1	0	3	5			
07:45 - 08:00	PKW	49	9	4	13	16	24			
	KRAD	0	0	0	0	0	0			
	LIEFERWAGEN	5	5	4	2	4	5			
	LKW	1	2	4	5	2	5			
08:00 - 08:15	PKW	28	6	0	10	4	25			
	KRAD	0	0	0	0	0	0			
	LIEFERWAGEN	2	0	3	4	1	3			
	LKW	2	2	1	1	0	8			
08:15 - 08:30	PKW	14	6	2	5	4	15			
	KRAD	0	0	0	0	0	0			
	LIEFERWAGEN	1	2	1	3	2	1			
	LKW	1	2	1	0	1	1			
08:30 - 08:45	PKW	28	6	2	4	5	13			
	KRAD	1	0	0	0	0	0			
	LIEFERWAGEN	1	0	3	1	2	5			
	LKW	3	1	0	1	1	3			
08:45 - 09:00	PKW	21	7	1	5	3	23			
	KRAD	0	0	0	0	0	0			
	LIEFERWAGEN	7	2	2	2	4	2			
	LKW	2	1	3	2	0	3			
09:00 - 09:15	PKW	22	7	7	4	5	10			
	KRAD	0	0	0	0	0	0			
	LIEFERWAGEN	5	1	1	0	3	1			
	LKW	4	0	1	1	1	4			
09:15 - 09:30	PKW	8	3	7	6	8	20			
	KRAD	0	0	0	0	0	0			
	LIEFERWAGEN	0	1	2	2	2	4			
	LKW	4	0	1	2	1	3			
09:30 - 09:45	PKW	20	3	7	5	3	12			
	KRAD	0	0	0	0	0	0			
	LIEFERWAGEN	3	0	2	0	1	4			
	LKW	9	2	5	1	2	3			
09:45 - 10:00	PKW	18	5	0	2	3	26			
	KRAD	0	0	0	0	0	0			
	LIEFERWAGEN	3	2	0	1	2	4			
	LKW	4	0	4	1	2	4			

Intervall	Fz-Arten	Wellener Landstraße		Südstraße		Wellener Landstraße					
		GA	RA	LE	RE	LA	GE				
		2	3	4	6	7	8				
15:00 - 15:15	PKW	22	7	4	7	5	32				
	KRAD	0	0	0	0	0	1				
	LIEFERWAGEN	2	1	2	3	3	5				
	LKW	5	3	3	3	0	7				
15:15 - 15:30	PKW	18	8	5	5	4	43				
	KRAD	0	0	0	0	0	0				
	LIEFERWAGEN	6	2	5	3	2	6				
	LKW	1	1	1	3	2	9				
15:30 - 15:45	PKW	28	11	12	8	7	44				
	KRAD	0	0	0	0	0	0				
	LIEFERWAGEN	4	0	1	1	2	3				
	LKW	6	1	3	1	2	2				
15:45 - 16:00	PKW	35	5	7	6	11	37				
	KRAD	0	0	0	0	0	0				
	LIEFERWAGEN	4	1	1	2	0	6				
	LKW	7	2	3	2	1	9				
16:00 - 16:15	PKW	26	12	13	5	10	45				
	KRAD	0	0	0	0	0	0				
	LIEFERWAGEN	8	1	1	2	3	5				
	LKW	7	4	0	0	3	4				
16:15 - 16:30	PKW	25	5	12	4	6	65				
	KRAD	0	0	0	0	0	0				
	LIEFERWAGEN	4	2	4	2	1	4				
	LKW	3	0	1	1	4	5				
16:30 - 16:45	PKW	32	6	16	8	15	38				
	KRAD	0	0	0	2	0	1				
	LIEFERWAGEN	7	1	3	0	2	4				
	LKW	3	0	1	1	0	1				
16:45 - 17:00	PKW	29	5	12	11	9	42				
	KRAD	0	0	0	0	0	0				
	LIEFERWAGEN	9	0	0	0	2	6				
	LKW	1	4	1	2	1	1				
17:00 - 17:15	PKW	37	14	9	9	6	58				
	KRAD	0	0	0	0	1	0				
	LIEFERWAGEN	4	0	1	1	3	8				
	LKW	1	2	2	2	2	2				
17:15 - 17:30	PKW	38	8	12	5	9	47				
	KRAD	1	0	0	0	1	0				
	LIEFERWAGEN	8	0	1	1	3	5				
	LKW m.A.	0	2	0	1	2	0				
17:30 - 17:45	PKW	33	5	11	6	6	56				
	KRAD	1	0	0	0	0	0				
	LIEFERWAGEN	1	4	0	1	1	5				
	LKW	1	2	1	0	0	4				
17:45 - 18:00	PKW	44	6	9	4	7	44				
	KRAD	0	0	0	0	0	0				
	LIEFERWAGEN	0	0	0	1	0	3				
	LKW	4	0	0	1	0	5				
18:00 - 18:15	PKW	25	8	7	3	9	40				
	KRAD	1	0	0	0	0	0				
	LIEFERWAGEN	1	3	1	0	1	2				
	LKW	1	1	2	0	0	1				
18:15 - 18:30	PKW	19	5	9	2	5	30				
	KRAD	0	1	0	0	0	1				
	LIEFERWAGEN	1	0	0	1	1	2				
	LKW	3	1	0	0	1	0				
18:30 - 18:45	PKW	27	3	4	5	6	31				
	KRAD	0	0	0	0	0	0				
	LIEFERWAGEN	0	1	0	0	1	2				
	LKW	0	0	2	0	0	2				
18:45 - 19:00	PKW	19	3	3	1	9	34				
	KRAD	0	0	0	0	0	0				
	LIEFERWAGEN	2	0	1	1	0	0				
	LKW	0	1	0	1	0	0				

Knotenpunkt 5

Wellener Landstraße L491/Südstraße

Intervall	Fz-Arten	Wellener Landstraße			Südstraße			Wellener Landstraße				
		LA	GA	RA	LE	RE	LA	GE				
Hochrechnung DTV			2	3	4		6	7	8			
Summe Kfz/4h (6-10)			527	114	99		130	128	399			
Summe Pkw/4h (6-10)			434	87	51		91	87	304			
Summe Lkw/4h (6-10)			93	27	48		39	41	95			
Summe Kfz/4h (15-19)			564	152	186		128	169	807			
Summe Pkw/4h (15-19)			460	112	145		91	126	689			
Summe Lkw/4h (15-19)			104	38	41		36	41	118			
DTV 24 Stunden			2	3	4		6	7	8			
Morgens Kfz 21%			2462	533	463		607	598	1864			
Morgens Lkw 30%			309	90	159		130	136	316			
Nachmittags Kfz 33%			1686	454	556		383	505	2413			
Nachmittags Lkw 27%			392	143	155		136	155	445			
Mittelwert aus mo und na			2074	494	509		495	552	2138			
Lkw-Anteil mit Lieferverkehr			351	116	157		133	145	380			
Lkw-Anteil mit Lieferverkehr in %			17%	24%	31%		27%	26%	18%			
davon mo	PKW		431	87	51		91	87	303			
	KRAD		3	0	0		0	0	1			
	LIEFERWAGEN		51	14	25		20	25	42			
	LKW		42	13	23		19	16	53			
davon	PKW		457	111	145		89	124	686			
	KRAD		3	1	0		2	2	3			
	LIEFERWAGEN		61	16	21		19	25	66			
	LKW		43	22	20		17	16	52			

Graphische Darstellung der DTV-Werte (Mittelwert aus mo und na):

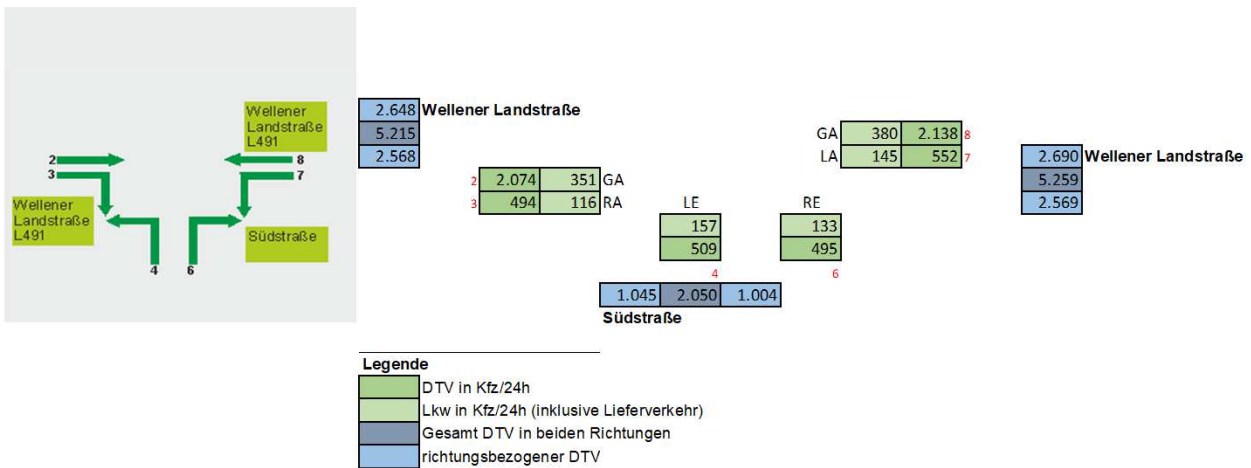

Graphische Darstellung der Spitzenstundenwerte morgens (7:00 - 8:00)

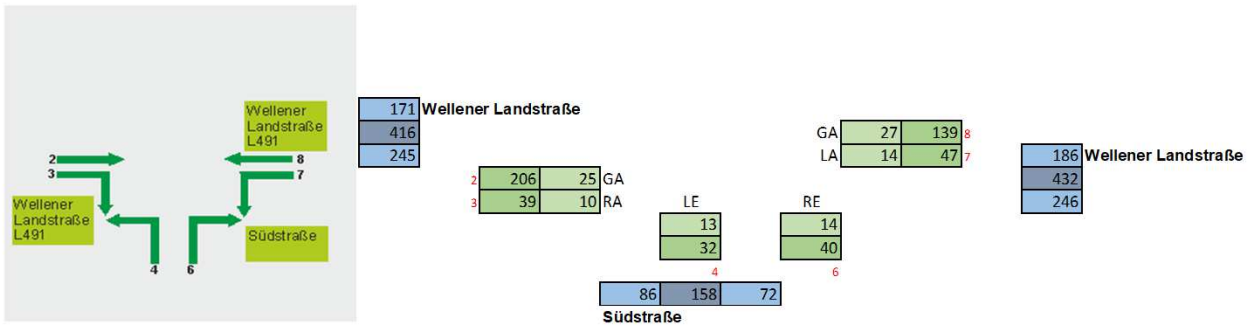

Graphische Darstellung der Spitzenstundenwerte nachmittags (17:00 - 18:00)

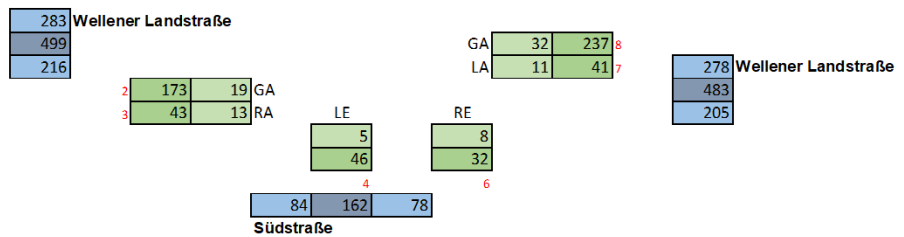

- Legende**
- Kfz/Spitzenstunde
 - Lkw/Spitzenstunde (inklusive Lieferverkehr)
 - Kfz/Spitzenstunde gesamt
 - Kfz/Spitzenstunde richtungsbezogen

Knotenpunkt 6

Weller Landstraße L361/Walbecker Straße/Weller Landstraße L491

September 2019

2 mal 4 Stunden-Zählung

Datum der Zählung: Do. 17.09.2019

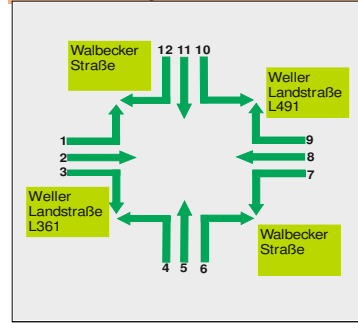

Intervall	Fz-Arten	Weller Landstraße L361			Walbecker Straße			Weller Landstraße L491			Walbecker Straße		
		LA	GA	RA	LE	GE	RE	LA	GE	RA	LE	GE	RE
		1	2	3	4	5	6	7	8	9	10	11	12
06:00 - 06:15	PKW	0	8	3	0	1	5	3	2	0	9	19	1
	KRAD	0	0	0	0	0	0	1	0	0	0	0	0
	LIEFERWAGEN	0	0	2	0	0	1	1	1	0	1	0	0
	LKW	0	0	2	0	0	0	1	2	0	0	0	0
06:15 - 06:30	PKW	0	15	10	5	4	0	7	4	1	7	38	1
	KRAD	0	0	0	0	0	0	0	0	0	0	0	0
	LIEFERWAGEN	0	2	1	0	0	0	0	1	0	0	2	0
	LKW	0	2	2	0	0	0	4	1	0	0	0	0
06:30 - 06:45	PKW	1	17	16	4	9	2	12	11	1	11	41	1
	KRAD	0	0	1	0	0	0	0	0	0	0	4	0
	LIEFERWAGEN	0	0	0	0	0	2	3	0	0	1	4	0
	LKW	0	0	0	0	0	1	4	0	0	0	0	0
06:45 - 07:00	PKW	0	16	15	6	11	6	4	7	1	10	39	5
	KRAD	0	0	0	0	0	0	0	0	0	0	0	0
	LIEFERWAGEN	1	2	2	1	2	1	0	1	2	3	2	0
	LKW	0	0	5	4	0	3	1	2	0	0	0	0
07:00 - 07:15	PKW	1	18	16	6	14	9	15	13	2	23	50	7
	KRAD	0	0	0	0	0	1	0	0	0	0	2	0
	LIEFERWAGEN	0	2	2	0	1	0	3	1	0	2	3	0
	LKW	0	0	6	1	0	0	2	0	0	1	0	0
07:15 - 07:30	PKW	1	23	14	5	17	15	13	19	4	21	54	8
	KRAD	0	0	0	0	0	0	0	0	0	0	0	0
	LIEFERWAGEN	1	3	1	2	6	1	2	1	1	1	4	0
	LKW	0	0	1	3	0	1	0	0	0	0	3	0
07:30 - 07:45	PKW	0	18	30	5	19	8	13	14	7	19	48	7
	KRAD	0	0	0	0	1	1	0	0	1	0	1	0
	LIEFERWAGEN	1	1	2	2	0	0	2	3	0	3	2	1
	LKW	0	4	4	4	0	2	4	2	0	0	0	0
07:45 - 08:00	PKW	3	21	27	7	16	8	16	11	3	26	63	6
	KRAD	0	0	0	0	0	0	0	0	0	0	0	0
	LIEFERWAGEN	0	5	1	1	1	1	2	6	1	4	6	1
	LKW	0	2	1	3	0	1	8	1	0	0	0	0
08:00 - 08:15	PKW	4	10	13	4	14	10	8	13	4	12	23	1
	KRAD	0	0	0	0	0	0	0	0	0	0	0	0
	LIEFERWAGEN	0	0	2	2	3	2	1	1	2	0	5	0
	LKW	0	0	3	4	0	3	8	1	0	0	0	0
08:15 - 08:30	PKW	1	11	13	6	19	4	7	6	4	7	28	4
	KRAD	0	0	0	0	0	0	0	0	0	0	0	0
	LIEFERWAGEN	0	0	2	0	4	3	2	1	1	0	1	0
	LKW	0	3	2	5	0	1	1	1	0	0	0	0
08:30 - 08:45	PKW	2	17	10	8	18	7	4	6	5	12	26	7
	KRAD	0	1	0	0	0	0	0	0	0	0	0	0
	LIEFERWAGEN	1	0	2	0	4	1	1	2	4	0	1	0
	LKW	0	2	3	4	0	1	2	1	0	0	1	0
08:45 - 09:00	PKW	1	12	4	4	19	7	7	12	4	8	22	3
	KRAD	0	0	0	0	1	0	0	0	0	0	0	0
	LIEFERWAGEN	0	0	1	2	4	2	3	0	2	2	1	0
	LKW	0	1	1	1	0	3	3	3	0	0	0	0
09:00 - 09:15	PKW	1	14	10	4	24	2	4	7	4	11	11	3
	KRAD	0	0	0	0	0	0	0	0	0	0	0	0
	LIEFERWAGEN	1	3	0	1	5	1	1	1	0	3	1	0
	LKW	0	2	1	3	0	1	3	1	1	0	1	0
09:15 - 09:30	PKW	2	6	3	3	20	3	4	18	6	4	15	3
	KRAD	0	0	0	0	0	0	0	0	0	0	0	0
	LIEFERWAGEN	0	0	2	1	3	0	2	1	3	0	2	0
	LKW	0	1	1	4	0	7	2	1	0	0	1	0
09:30 - 09:45	PKW	2	11	6	3	14	4	5	13	3	6	22	4
	KRAD	0	0	0	0	0	0	0	0	0	0	0	0
	LIEFERWAGEN	0	0	0	0	3	1	3	1	2	2	0	0
	LKW	0	6	2	2	1	1	5	3	1	0	0	0
09:45 - 10:00	PKW	1	9	5	4	10	9	5	14	4	5	14	2
	KRAD	0	0	0	0	1	0	0	0	0	0	0	0
	LIEFERWAGEN	0	5	1	1	2	0	1	2	1	0	4	2
	LKW	1	2	0	1	0	2	4	4	0	0	0	0

Knotenpunkt 6

Weller Landstraße L361/Walbecker Straße/Weller Landstraße L491

Intervall	Fz-Arten	Weller Landstraße L361			Walbecker Straße			Weller Landstraße L491			Walbecker Straße		
		LA	GA	RA	LE	GE	RE	LA	GE	RA	LE	GE	RE
		1	2	3	4	5	6	7	8	9	10	11	12
Hochrechnung DTV													
Summe Kfz/4h (6-10)		26	275	251	126	271	144	207	216	75	214	564	67
Summe Pkw/4h (6-10)		20	227	196	74	232	101	128	170	54	191	520	63
Summe Lkw/4h (6-10)		6	48	55	52	39	43	79	46	21	23	44	4
Summe Kfz/4h (15-19)		83	329	156	246	696	210	211	461	320	170	408	87
Summe Pkw/4h (15-19)		79	272	116	177	646	150	147	393	293	146	378	79
Summe Lkw/4h (15-19)		4	57	40	68	50	58	63	68	27	24	29	7
DTV 24 Stunden		1	2	3	4	5	6	7	8	9	10	11	12
Morgens Kfz	21%	121	1285	1173	589	1266	673	967	1009	350	1000	2635	313
Morgens Lkw	30%	20	159	183	173	130	143	262	153	70	76	146	13
Nachmittags Kfz	33%	248	984	466	735	2081	628	631	1378	957	508	1220	260
Nachmittags Lkw	27%	15	215	151	256	189	219	238	256	102	90	109	26
Mittelwert aus mo und na		185	1134	820	662	1673	650	799	1194	654	754	1927	287
Lkw-Anteil mit Lieferverkehr		18	187	167	215	159	181	250	205	86	83	128	20
Lkw-Anteil mit Lieferverkehr in %		9%	17%	20%	32%	10%	28%	31%	17%	13%	11%	7%	7%

davon mo	PKW	20	226	195	74	229	99	127	170	53	191	513	63
	KRAD	0	1	1	0	3	2	1	0	1	0	7	0
	LIEFERWAGEN	5	23	21	13	38	16	27	23	19	22	38	4
	LKW	1	25	34	39	1	27	52	23	2	1	6	0

davon na	PKW	79	271	116	175	634	149	144	393	293	144	372	78
	KRAD	0	1	0	2	12	1	3	0	0	2	6	1
	LIEFERWAGEN	4	36	20	27	46	17	15	45	27	23	25	7
	LKW	0	21	20	41	4	41	48	23	0	1	4	0

Graphische Darstellung der DTV-Werte (Mittelwert aus mo und na):

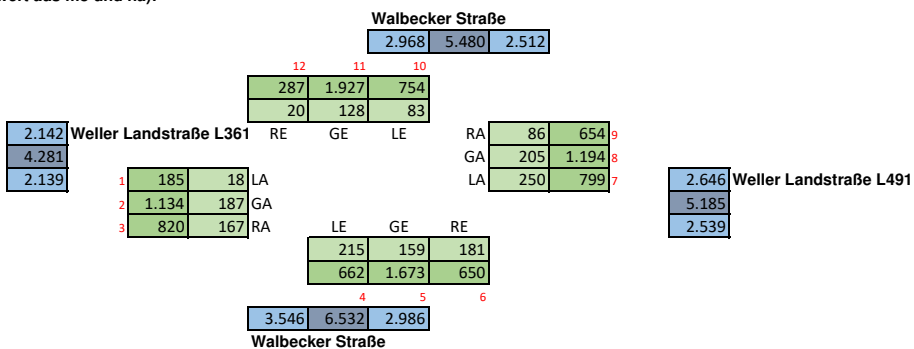
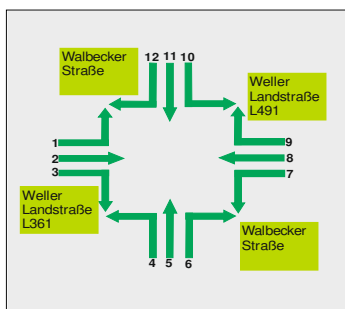

- Legende**
- DTV in Kfz/24h
 - Lkw in Kfz/24h (inklusive Lieferverkehr)
 - Gesamt DTV in beiden Richtungen
 - richtungsbezogener DTV

Graphische Darstellung der Spitzenstundenwerte morgens (7:00 - 8:00)

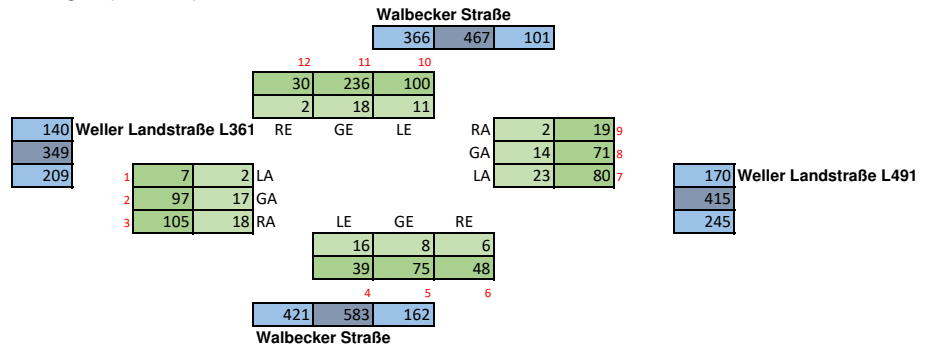
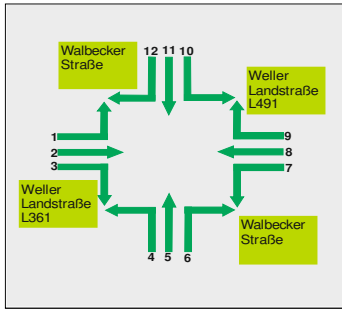

Graphische Darstellung der Spitzenstundenwerte nachmittags (17:00 - 18:00)

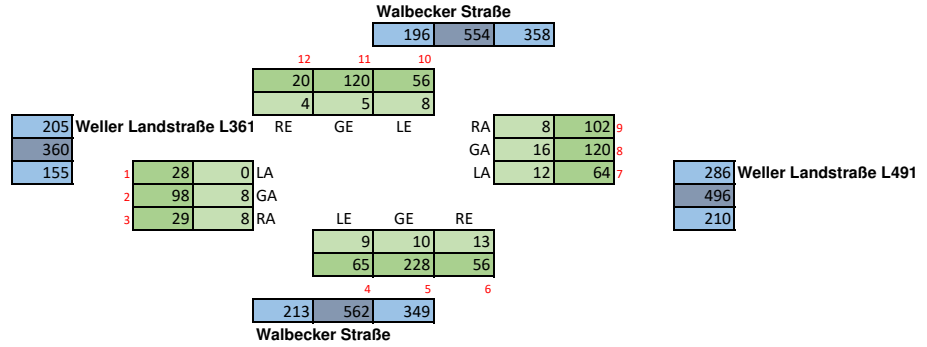

- Legende**
- Kfz/Spitzenstunde
 - Lkw/Spitzenstunde (inklusive Lieferverkehr)
 - Kfz/Spitzenstunde gesamt
 - Kfz/Spitzenstunde richtungsbezogen

Knotenpunkt 7

Weller Landstraße L261/Twistedener Straße K36

September 2019

2 mal 4 Stunden-Zählung

Datum der Zählung: Do. 17.09.2019

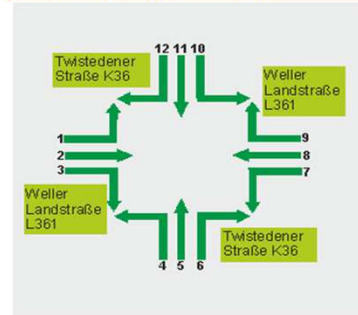

Intervall	Fz-Arten	Weller Landstraße L361			Twistedener Straße K36			Weller Landstraße L361			Twistedener Straße K36		
		LA	GA	RA	LE	GE	RE	LA	GE	RA	LE	GE	RE
		1	2	3	4	5	6	7	8	9	10	11	12
06:00 - 06:15	PKW	0	8	4	0	0	3	0	2	0	1	2	0
	KRAD	0	0	0	0	0	0	0	0	0	0	0	0
	LIEFERWAGEN	0	0	0	0	0	0	1	0	0	0	0	0
	LKW	0	2	0	0	0	0	2	1	0	0	0	0
06:15 - 06:30	PKW	0	15	2	0	0	10	3	7	1	2	2	0
	KRAD	0	0	0	0	0	0	0	0	0	0	0	0
	LIEFERWAGEN	0	3	0	1	0	0	0	0	0	0	0	0
	LKW	0	3	0	0	0	1	0	0	0	0	0	0
06:30 - 06:45	PKW	1	26	6	1	6	2	4	12	0	3	5	0
	KRAD	0	0	0	0	1	0	0	0	0	1	0	0
	LIEFERWAGEN	0	1	0	1	1	0	0	1	0	1	0	0
	LKW	0	0	0	0	1	0	0	1	0	0	0	0
06:45 - 07:00	PKW	0	19	3	2	5	3	3	11	2	8	11	1
	KRAD	0	0	0	0	0	0	0	0	0	0	0	0
	LIEFERWAGEN	0	4	2	0	1	1	0	2	0	0	2	0
	LKW	0	4	0	0	1	1	0	6	0	0	1	0
07:00 - 07:15	PKW	1	19	0	0	11	7	2	14	7	8	1	3
	KRAD	0	0	0	0	0	0	0	0	0	0	0	0
	LIEFERWAGEN	0	2	0	0	4	2	0	1	0	0	1	0
	LKW	0	6	0	0	0	0	0	1	0	0	0	0
07:15 - 07:30	PKW	1	28	6	1	9	6	8	21	3	8	4	7
	KRAD	0	0	0	0	0	0	0	0	0	0	0	0
	LIEFERWAGEN	0	2	0	0	1	2	0	3	0	2	3	0
	LKW	0	1	0	0	1	0	0	3	0	0	1	0
07:30 - 07:45	PKW	1	27	1	4	19	9	4	15	13	10	9	4
	KRAD	0	0	0	0	4	0	0	0	0	0	1	0
	LIEFERWAGEN	0	2	0	0	3	1	2	3	1	0	0	0
	LKW	0	4	1	0	2	1	0	5	1	1	0	0
07:45 - 08:00	PKW	3	27	5	4	14	5	6	12	7	13	16	2
	KRAD	0	0	0	0	2	0	0	0	0	0	0	0
	LIEFERWAGEN	0	5	2	0	1	0	1	7	0	1	0	0
	LKW	0	5	0	0	1	0	0	3	1	0	1	0
08:00 - 08:15	PKW	1	16	4	4	15	6	2	8	8	8	3	2
	KRAD	0	0	0	0	0	0	0	0	0	0	0	0
	LIEFERWAGEN	0	2	0	0	1	0	0	3	0	0	1	0
	LKW	0	3	0	1	0	0	1	4	0	0	0	0
08:15 - 08:30	PKW	3	15	2	2	11	4	4	10	5	4	4	3
	KRAD	0	0	0	0	0	0	0	0	0	0	0	0
	LIEFERWAGEN	0	2	0	0	0	1	1	1	0	0	2	0
	LKW	0	5	0	0	1	0	0	6	0	0	0	0
08:30 - 08:45	PKW	0	16	3	5	16	7	3	8	7	8	6	1
	KRAD	0	1	0	0	0	0	0	0	0	0	0	0
	LIEFERWAGEN	0	2	1	0	2	0	0	1	0	0	2	1
	LKW	0	3	0	0	1	1	0	5	0	1	0	0
08:45 - 09:00	PKW	2	9	2	3	13	7	6	8	6	3	7	4
	KRAD	0	0	0	0	0	0	0	0	0	0	0	0
	LIEFERWAGEN	0	0	1	0	0	3	1	1	0	1	1	1
	LKW	0	2	0	0	0	0	0	4	0	0	1	0
09:00 - 09:15	PKW	1	15	1	2	16	4	3	11	1	5	6	1
	KRAD	0	0	0	0	0	0	0	0	0	0	0	0
	LIEFERWAGEN	0	3	0	0	0	1	0	1	0	0	1	0
	LKW	0	2	1	0	0	1	0	4	0	0	0	0
09:15 - 09:30	PKW	0	5	4	5	14	2	9	10	2	4	12	0
	KRAD	0	0	0	0	0	0	0	0	0	0	0	0
	LIEFERWAGEN	0	2	0	0	2	0	1	2	0	0	2	0
	LKW	0	1	0	0	0	1	1	4	0	0	0	0
09:30 - 09:45	PKW	2	13	2	4	8	3	9	6	7	2	5	1
	KRAD	0	0	0	0	0	0	0	0	0	0	0	0
	LIEFERWAGEN	0	0	1	0	1	0	0	1	0	0	0	0
	LKW	0	3	0	0	1	5	1	4	0	0	0	0
09:45 - 10:00	PKW	2	9	7	2	8	4	5	13	0	4	16	1
	KRAD	0	0	0	0	0	0	0	0	0	0	0	0
	LIEFERWAGEN	0	4	0	0	0	1	1	4	0	1	2	0
	LKW	0	1	0	0	1	2	0	5	0	0	1	0

Intervall	Fz-Arten	Weller Landstraße L361			Twistedener Straße K36			Weller Landstraße L361			Twistedener Straße K36		
		LA	GA	RA	LE	GE	RE	LA	GE	RA	LE	GE	RE
		1	2	3	4	5	6	7	8	9	10	11	12
15:00 - 15:15	PKW	1	12	8	6	6	4	3	24	7	1	13	1
	KRAD	0	0	0	0	0	0	0	0	0	0	3	0
	LIEFERWAGEN	1	2	0	0	2	1	3	3	0	1	3	0
	LKW	0	3	1	2	0	2	0	10	1	2	0	0
15:15 - 15:30	PKW	4	13	9	3	18	10	5	13	8	6	14	3
	KRAD	1	0	0	0	0	0	0	0	0	0	1	0
	LIEFERWAGEN	0	2	1	0	0	1	1	6	1	1	1	0
	LKW	0	2	0	0	0	0	1	4	0	0	0	0
15:30 - 15:45	PKW	7	20	9	6	13	7	9	32	6	8	9	3
	KRAD	0	0	0	0	0	0	0	0	0	0	1	0
	LIEFERWAGEN	0	5	0	0	1	2	1	3	1	0	3	0
	LKW	0	7	0	0	1	0	0	6	0	0	0	0
15:45 - 16:00	PKW	4	23	9	1	19	5	8	22	10	7	19	0
	KRAD	0	0	0	0	2	0	0	1	0	0	1	1
	LIEFERWAGEN	0	0	0	0	3	1	4	3	2	2	0	0
	LKW	0	3	0	0	0	1	2	6	0	0	2	0
16:00 - 16:15	PKW	4	24	6	6	11	7	6	19	17	4	10	2
	KRAD	0	0	0	1	1	0	0	0	0	0	0	0
	LIEFERWAGEN	0	3	2	0	2	2	1	4	0	0	0	0
	LKW	0	3	0	0	0	2	0	8	0	0	0	0
16:15 - 16:30	PKW	3	16	6	4	7	4	14	29	5	8	13	3
	KRAD	0	0	0	0	0	0	0	0	0	0	0	0
	LIEFERWAGEN	0	3	1	1	0	2	1	3	2	0	1	0
	LKW	0	4	0	1	1	0	0	7	0	0	0	0
16:30 - 16:45	PKW	1	20	4	5	23	8	19	21	10	3	12	1
	KRAD	1	0	0	0	0	0	0	0	0	0	0	0
	LIEFERWAGEN	1	1	1	0	2	2	1	1	0	1	1	1
	LKW	0	3	0	0	1	1	1	2	0	0	0	0
16:45 - 17:00	PKW	4	14	6	5	18	12	10	30	6	4	16	3
	KRAD	0	0	0	0	2	0	0	1	1	0	1	0
	LIEFERWAGEN	0	5	2	1	0	1	0	4	1	0	1	0
	LKW	0	1	0	0	0	3	0	3	0	1	1	0
17:00 - 17:15	PKW	3	16	7	6	10	11	12	20	7	7	13	3
	KRAD	0	0	1	0	1	0	0	0	0	0	1	0
	LIEFERWAGEN	0	3	0	0	0	0	3	5	0	2	1	0
	LKW	0	0	0	0	0	1	0	3	0	0	0	0
17:15 - 17:30	PKW	3	15	6	4	12	10	12	33	4	2	12	1
	KRAD	0	0	0	0	1	0	0	0	0	0	0	0
	LIEFERWAGEN	0	4	0	1	2	2	0	4	1	0	1	0
	LKW m.A.	0	0	0	0	1	0	1	1	0	0	0	0
17:30 - 17:45	PKW	2	19	3	3	17	11	11	21	15	3	6	5
	KRAD	0	1	0	0	0	0	0	0	0	0	0	0
	LIEFERWAGEN	0	2	0	1	1	1	0	3	1	0	0	0
	LKW	0	0	0	0	1	0	0	2	0	0	1	0
17:45 - 18:00	PKW	1	20	10	11	17	19	10	21	11	0	8	4
	KRAD	0	0	0	0	0	0	0	0	0	0	1	0
	LIEFERWAGEN	1	0	0	0	1	1	1	3	0	1	1	0
	LKW	0	2	0	0	0	0	2	0	0	0	1	0
18:00 - 18:15	PKW	2	21	6	2	13	4	7	27	9	3	16	1
	KRAD	1	0	0	0	0	0	0	0	0	0	1	0
	LIEFERWAGEN	0	4	0	1	0	1	2	3	0	0	1	0
	LKW	0	0	0	0	1	0	1	1	0	0	0	0
18:15 - 18:30	PKW	1	10	9	5	13	3	9	14	9	2	11	4
	KRAD	0	0	0	0	0	0	0	0	0	0	0	0
	LIEFERWAGEN	0	1	0	1	1	0	0	3	1	0	3	0
	LKW	0	0	0	0	0	0	0	1	0	0	0	0
18:30 - 18:45	PKW	1	8	5	1	21	11	8	14	9	5	16	0
	KRAD	0	0	0	0	1	0	0	0	0	0	0	1
	LIEFERWAGEN	0	1	0	1	2	1	1	1	0	2	0	0
	LKW	0	0	0	0	1	0	0	2	0	0	1	0
18:45 - 19:00	PKW	3	13	5	3	13	9	11	11	9	0	11	2
	KRAD	0	0	0	0	1	0	0	0	0	0	0	0
	LIEFERWAGEN	0	2	0	1	0	0	1	0	0	0	0	0
	LKW	0	0	0	0	0	0	0	1	0	0	1	0

Knotenpunkt 7

Weller Landstraße L261/Twistedener Straße K36

Intervall	Fz-Arten	Weller Landstraße L361			Twistedener Straße K36			Weller Landstraße L361			Twistedener Straße K36		
		LA	GA	RA	LE	GE	RE	LA	GE	RA	LE	GE	RE
		1	2	3	4	5	6	7	8	9	10	11	12
Hochrechnung DTV													
Summe Kfz/4h (6-10)		18	347	61	42	199	107	84	255	72	100	132	32
Summe Pkw/4h (6-10)		18	268	52	39	172	82	71	168	69	92	110	30
Summe Lkw/4h (6-10)		0	79	9	3	27	25	13	87	3	8	22	2
Summe Kfz/4h (15-19)		50	331	117	83	264	163	182	459	154	76	233	39
Summe Pkw/4h (15-19)		47	265	109	72	240	135	154	353	143	63	209	38
Summe Lkw/4h (15-19)		3	66	8	11	23	28	27	105	11	13	24	1
DTV 24 Stunden		1	2	3	4	5	6	7	8	9	10	11	12
Morgens Kfz	21%	84	1621	285	196	930	500	392	1191	336	467	617	150
Morgens Lkw	30%	0	262	30	10	90	83	43	289	10	27	73	7
Nachmittags Kfz	33%	149	990	350	248	789	487	544	1372	460	227	697	117
Nachmittags Lkw	27%	11	249	30	41	87	106	102	396	41	49	90	4
Mittelwert aus mo und na		117	1305	317	222	860	494	468	1282	398	347	657	133
Lkw-Anteil mit Lieferverkehr		6	256	30	26	88	94	73	342	26	38	82	5
Lkw-Anteil mit Lieferverkehr in %		5%	20%	9%	12%	10%	19%	15%	27%	6%	11%	12%	4%
davon mo	PKW	18	267	52	39	165	82	71	168	69	91	109	30
	KRAD	0	1	0	0	7	0	0	0	0	1	1	0
	LIEFERWAGEN	0	34	7	2	17	12	8	31	1	6	17	2
	LKW	0	45	2	1	10	13	5	56	2	2	5	0
davon	PKW	44	264	108	71	231	135	154	351	142	63	199	36
	KRAD	3	1	1	1	9	0	0	2	1	0	10	2
	LIEFERWAGEN	3	38	7	8	17	18	20	49	10	10	17	1
	LKW	0	28	1	3	6	10	7	56	1	3	7	0

Graphische Darstellung der DTV-Werte (Mittelwert aus mo und na):

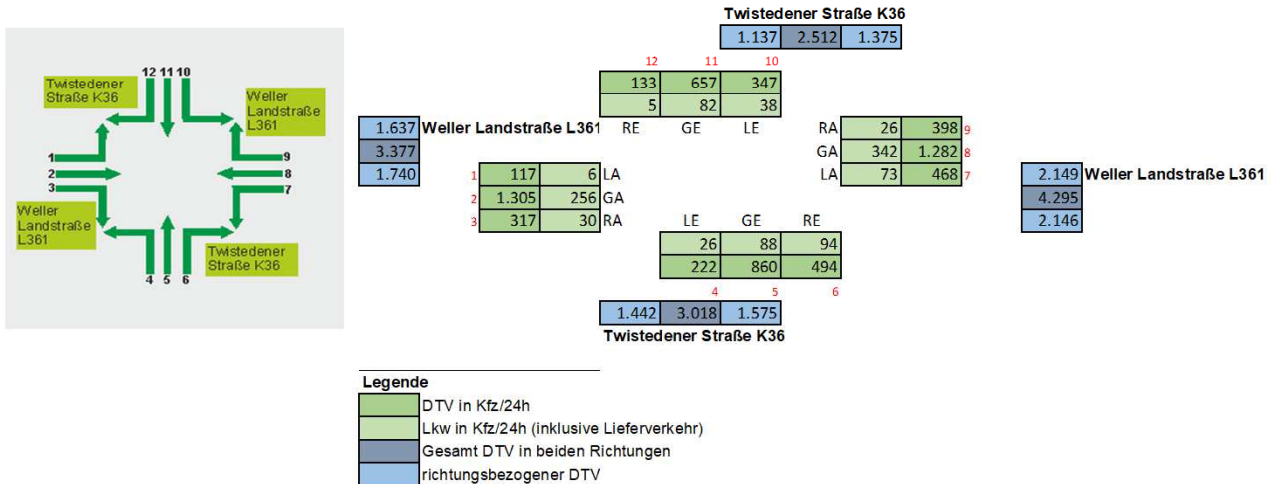

Graphische Darstellung der Spitzenstundenwerte morgens (7:00 - 8:00)

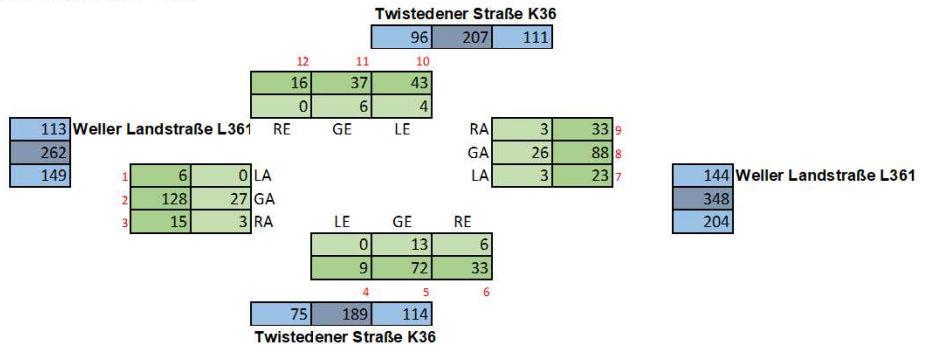
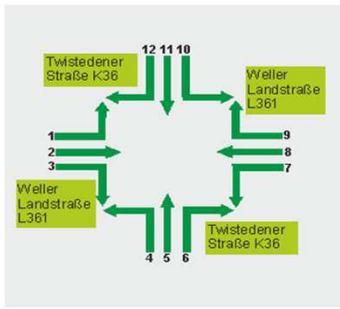

Graphische Darstellung der Spitzenstundenwerte nachmittags (17:00 - 18:00)

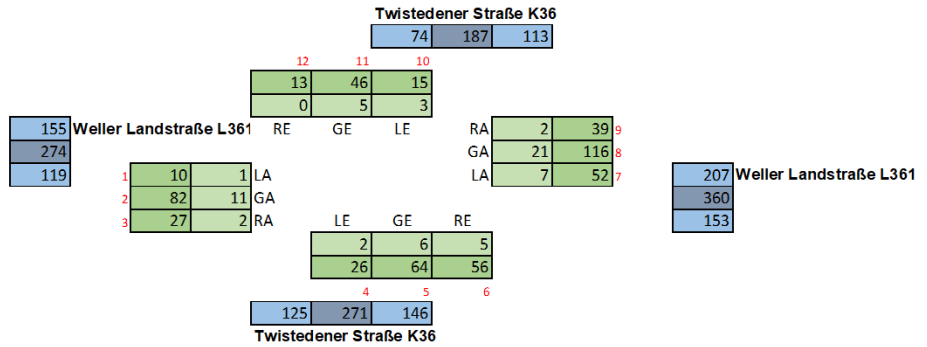

- Legende**
- Kfz/Spitzenstunde
 - Lkw/Spitzenstunde (inklusive Lieferverkehr)
 - Kfz/Spitzenstunde gesamt
 - Kfz/Spitzenstunde richtungsbezogen

Knotenpunkt 8

Weller Landstraße L261/Wember Straße

September 2019

2 mal 4 Stunden-Zählung

Datum der Zählung: Do. 17.09.2019

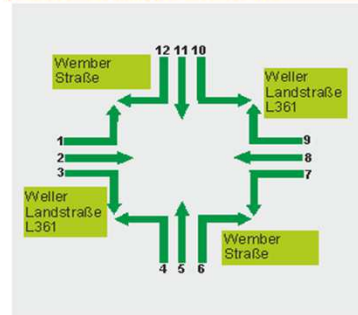

Intervall	Fz-Arten	Weller Landstraße L361			Wember Straße			Weller Landstraße L361			Wember Straße		
		LA	GA	RA	LE	GE	RE	LA	GE	RA	LE	GE	RE
		1	2	3	4	5	6	7	8	9	10	11	12
06:00 - 06:15	PKW	1	5	0	0	0	0	0	2	0	7	0	7
	KRAD	0	0	0	0	0	0	0	0	0	0	0	0
	LIEFERWAGEN	0	0	0	0	0	0	0	0	0	0	0	0
	LKW	0	2	0	0	0	1	0	1	0	0	0	0
06:15 - 06:30	PKW	2	8	0	0	0	0	0	7	3	9	0	13
	KRAD	0	0	0	0	0	0	0	0	0	0	0	0
	LIEFERWAGEN	0	1	0	0	0	0	0	1	0	0	0	0
	LKW	0	1	0	0	0	0	0	0	0	1	0	0
06:30 - 06:45	PKW	6	17	0	0	0	1	0	6	4	15	0	8
	KRAD	0	0	0	0	0	0	0	0	0	0	0	0
	LIEFERWAGEN	0	0	0	0	0	0	0	2	0	1	0	0
	LKW	0	0	0	0	0	0	0	1	1	2	0	0
06:45 - 07:00	PKW	3	11	0	0	0	1	1	12	2	10	1	8
	KRAD	0	0	0	0	0	0	0	0	0	0	0	0
	LIEFERWAGEN	0	5	0	0	0	0	0	2	1	1	0	0
	LKW	0	1	0	0	0	1	0	4	1	2	0	0
07:00 - 07:15	PKW	2	14	0	0	0	0	2	15	0	10	1	8
	KRAD	0	0	0	0	0	0	0	0	0	0	0	0
	LIEFERWAGEN	0	1	0	0	0	0	0	1	1	1	0	0
	LKW	0	4	0	0	0	0	0	0	1	2	0	0
07:15 - 07:30	PKW	4	17	0	0	0	1	1	20	6	13	0	10
	KRAD	0	0	0	0	0	0	0	0	0	0	0	0
	LIEFERWAGEN	2	0	0	0	0	0	0	1	1	1	0	0
	LKW	1	0	0	0	0	0	0	0	3	1	0	0
07:30 - 07:45	PKW	7	15	0	0	0	1	1	15	8	13	1	13
	KRAD	0	0	0	0	0	0	0	0	0	0	0	0
	LIEFERWAGEN	1	0	0	0	0	0	0	2	0	2	0	0
	LKW	2	4	0	0	0	0	0	1	3	2	0	0
07:45 - 08:00	PKW	9	19	0	0	1	1	0	12	5	15	0	12
	KRAD	1	0	0	0	0	0	0	0	0	0	0	0
	LIEFERWAGEN	1	2	0	0	0	0	0	7	0	4	0	0
	LKW	0	3	0	0	0	0	0	3	1	2	0	0
08:00 - 08:15	PKW	5	9	0	0	1	0	0	10	5	15	0	8
	KRAD	0	0	0	0	0	0	0	0	0	0	0	0
	LIEFERWAGEN	1	0	0	0	0	0	0	2	1	2	0	0
	LKW	1	2	0	0	0	0	1	2	2	1	1	0
08:15 - 08:30	PKW	9	11	0	0	0	0	0	11	3	6	0	11
	KRAD	0	0	0	0	0	0	0	0	0	0	0	0
	LIEFERWAGEN	0	1	0	0	0	0	0	0	1	0	1	1
	LKW	1	5	0	0	0	0	0	4	2	1	0	0
08:30 - 08:45	PKW	11	12	0	0	0	0	0	5	7	7	0	10
	KRAD	0	1	0	0	0	0	0	0	0	0	0	0
	LIEFERWAGEN	0	1	0	0	0	1	0	2	0	1	0	0
	LKW	0	1	0	0	0	0	0	4	1	2	0	2
08:45 - 09:00	PKW	7	12	0	0	0	0	0	11	4	2	0	4
	KRAD	0	0	0	0	0	0	0	0	0	0	0	0
	LIEFERWAGEN	1	0	0	0	0	0	1	0	1	0	0	0
	LKW	2	1	0	0	0	0	0	3	1	1	0	0
09:00 - 09:15	PKW	8	8	0	0	0	0	0	12	4	5	0	7
	KRAD	0	0	0	0	0	0	0	0	0	0	0	0
	LIEFERWAGEN	1	1	0	0	1	0	0	1	0	2	0	1
	LKW	0	4	0	0	0	0	0	3	1	0	1	1
09:15 - 09:30	PKW	7	4	0	0	1	0	0	6	8	7	1	7
	KRAD	0	0	0	0	0	0	0	0	0	0	0	1
	LIEFERWAGEN	1	1	0	0	0	0	1	1	0	1	0	3
	LKW	0	0	0	0	0	0	0	4	0	1	0	1
09:30 - 09:45	PKW	5	13	0	0	0	1	0	8	4	4	3	9
	KRAD	0	0	0	0	0	0	0	0	0	0	0	0
	LIEFERWAGEN	0	1	0	0	0	0	0	1	0	0	0	0
	LKW	1	3	0	0	0	0	0	4	0	0	0	0
09:45 - 10:00	PKW	8	9	0	0	0	0	3	9	4	8	1	6
	KRAD	0	0	0	0	0	0	0	0	0	0	0	1
	LIEFERWAGEN	1	2	0	0	0	0	0	3	0	1	0	2
	LKW	1	1	0	0	0	0	0	5	0	1	1	0

Intervall	Fz-Arten	Weller Landstraße L361			Wember Straße			Weller Landstraße L361			Wember Straße		
		LA	GA	RA	LE	GE	RE	LA	GE	RA	LE	GE	RE
		1	2	3	4	5	6	7	8	9	10	11	12
15:00 - 15:15	PKW	13	14	0	0	0	0	1	14	17	8	0	12
	KRAD	0	0	0	0	0	0	0	0	0	0	0	0
	LIEFERWAGEN	4	1	0	0	0	0	0	2	1	1	0	2
	LKW	0	3	0	0	0	0	0	8	3	0	0	0
15:15 - 15:30	PKW	18	13	1	0	1	0	0	18	5	15	1	17
	KRAD	0	1	0	0	0	0	0	0	0	0	0	0
	LIEFERWAGEN	0	1	0	0	0	0	0	3	3	2	0	0
	LKW	0	2	0	0	0	0	1	4	0	1	0	0
15:30 - 15:45	PKW	21	17	0	0	0	0	0	26	11	12	0	11
	KRAD	0	0	0	0	0	0	0	0	0	0	0	0
	LIEFERWAGEN	0	4	0	0	0	0	0	2	1	2	0	2
	LKW	1	6	0	0	0	0	0	5	0	0	0	0
15:45 - 16:00	PKW	21	27	0	0	0	0	2	14	8	14	0	22
	KRAD	0	0	0	0	0	0	0	2	0	0	0	0
	LIEFERWAGEN	2	1	0	0	1	0	0	3	1	1	0	1
	LKW	2	3	0	0	0	0	1	6	0	0	0	0
16:00 - 16:15	PKW	22	23	0	0	1	2	0	15	12	8	1	20
	KRAD	0	0	0	0	0	0	0	0	1	0	0	1
	LIEFERWAGEN	0	2	0	0	0	0	0	0	1	2	0	2
	LKW	2	2	0	0	0	0	0	6	1	0	0	0
16:15 - 16:30	PKW	12	15	0	0	0	1	0	21	11	6	0	15
	KRAD	0	0	0	0	0	0	0	0	0	0	0	0
	LIEFERWAGEN	0	3	0	0	0	0	0	4	2	1	0	1
	LKW	0	4	0	0	0	0	0	8	0	0	0	0
16:30 - 16:45	PKW	14	19	0	0	0	0	0	17	12	8	0	14
	KRAD	0	1	0	0	0	0	0	0	0	0	0	0
	LIEFERWAGEN	2	2	0	0	0	0	0	3	1	1	0	2
	LKW	1	3	0	0	0	0	0	3	0	0	0	0
16:45 - 17:00	PKW	30	15	0	0	0	0	0	25	12	12	1	17
	KRAD	0	0	0	0	0	0	0	1	0	0	0	0
	LIEFERWAGEN	1	5	0	0	0	0	0	3	2	2	0	2
	LKW	0	1	0	0	0	0	0	2	1	0	0	1
17:00 - 17:15	PKW	20	15	0	0	0	0	1	18	11	8	0	14
	KRAD	1	0	0	0	0	0	0	0	0	1	0	0
	LIEFERWAGEN	4	2	0	0	0	0	0	4	1	2	0	0
	LKW	0	0	0	0	0	0	0	3	0	0	0	0
17:15 - 17:30	PKW	12	13	0	0	1	0	0	24	13	11	0	13
	KRAD	0	0	0	0	0	0	0	0	0	0	0	0
	LIEFERWAGEN	3	5	0	0	0	0	0	3	2	0	0	1
	LKW m.A.	0	0	0	0	0	0	0	1	0	0	0	0
17:30 - 17:45	PKW	19	15	0	0	1	1	0	21	6	10	0	21
	KRAD	0	1	0	0	0	0	0	0	0	0	0	0
	LIEFERWAGEN	1	4	0	0	0	0	0	3	1	0	0	1
	LKW	0	0	0	0	0	0	0	1	1	0	0	0
17:45 - 18:00	PKW	17	17	0	0	1	0	0	15	20	12	0	17
	KRAD	0	0	0	0	0	0	0	0	0	0	0	0
	LIEFERWAGEN	1	0	0	0	0	1	0	4	0	0	0	1
	LKW	0	1	0	0	0	0	0	0	0	1	0	0
18:00 - 18:15	PKW	15	17	1	0	0	0	1	16	12	11	0	10
	KRAD	0	1	0	0	0	0	0	0	0	0	0	1
	LIEFERWAGEN	0	4	0	0	0	0	0	3	1	0	0	2
	LKW	0	0	0	0	0	0	0	1	0	0	0	0
18:15 - 18:30	PKW	18	11	0	0	0	0	1	18	7	9	1	17
	KRAD	0	0	0	0	0	0	0	0	0	0	0	0
	LIEFERWAGEN	3	1	0	0	0	0	0	3	0	0	0	1
	LKW	0	0	0	0	0	0	0	1	0	0	0	0
18:30 - 18:45	PKW	13	8	0	0	1	1	0	10	4	5	2	3
	KRAD	0	0	0	0	0	0	0	1	0	0	0	0
	LIEFERWAGEN	2	2	0	0	0	0	0	2	0	0	0	1
	LKW	0	0	0	0	0	0	0	2	0	0	0	0
18:45 - 19:00	PKW	14	8	0	0	1	0	1	10	5	14	0	19
	KRAD	1	0	0	0	0	0	0	0	0	0	0	0
	LIEFERWAGEN	1	2	0	0	0	0	0	0	1	0	0	0
	LKW	0	0	0	0	0	0	0	1	0	0	0	2

Knotenpunkt 8

Weller Landstraße L261/Wember Straße

Intervall	Fz-Arten	Weller Landstraße L361			Wember Straße			Weller Landstraße L361			Wember Straße		
		LA	GA	RA	LE	GE	RE	LA	GE	RA	LE	GE	RE
		1	2	3	4	5	6	7	8	9	10	11	12
Hochrechnung DTV													
Summe Kfz/4h (6-10)		113	233	0	0	4	9	11	226	90	182	12	154
Summe Pkw/4h (6-10)		95	185	0	0	3	6	8	161	67	146	8	143
Summe Lkw/4h (6-10)		18	48	0	0	1	3	3	65	23	36	4	11
Summe Kfz/4h (15-19)		311	315	2	0	8	6	9	380	191	180	6	266
Summe Pkw/4h (15-19)		281	251	2	0	7	5	7	286	167	164	6	244
Summe Lkw/4h (15-19)		30	64	0	0	1	1	2	93	24	16	0	22
DTV 24 Stunden		1	2	3	4	5	6	7	8	9	10	11	12
Morgens Kfz	21%	528	1089	0	0	19	42	51	1056	420	850	56	720
Morgens Lkw	30%	60	159	0	0	3	10	10	216	76	120	13	37
Nachmittags Kfz	33%	930	942	6	0	24	18	27	1136	571	538	18	795
Nachmittags Lkw	27%	113	241	0	0	4	4	8	351	90	60	0	83
Mittelwert aus mo und na		729	1015	3	0	21	30	39	1096	496	694	37	757
Lkw-Anteil mit Lieferverkehr		86	200	0	0	4	7	9	283	83	90	7	60
Lkw-Anteil mit Lieferverkehr in %		12%	20%	0%	#DIV/0!	17%	23%	22%	26%	17%	13%	18%	8%
davon mo	PKW	94	184	0	0	3	6	8	161	67	146	8	141
	KRAD	1	1	0	0	0	0	0	0	0	0	0	2
	LIEFERWAGEN	9	16	0	0	1	1	2	26	6	17	1	7
	LKW	9	32	0	0	0	2	1	39	17	19	3	4
davon	PKW	279	247	2	0	7	5	7	282	166	163	6	242
	KRAD	2	4	0	0	0	0	0	4	1	1	0	2
	LIEFERWAGEN	24	39	0	0	1	1	0	42	18	14	0	19
	LKW	6	25	0	0	0	0	2	51	6	2	0	3

Graphische Darstellung der DTV-Werte (Mittelwert aus mo und na):

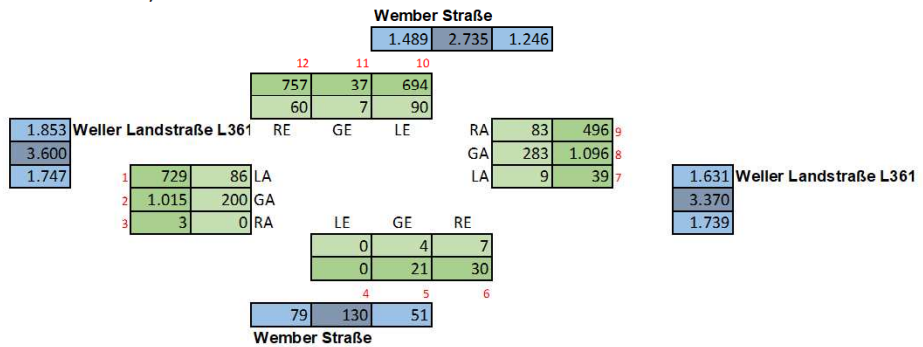
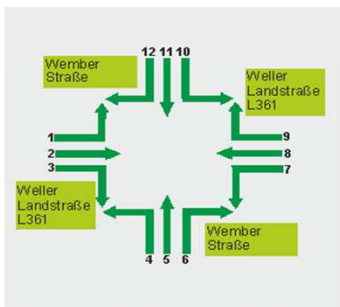

- Legende**
- DTV in Kfz/24h
 - Lkw in Kfz/24h (inklusive Lieferverkehr)
 - Gesamt DTV in beiden Richtungen
 - richtungsbezogener DTV

Graphische Darstellung der Spitzenstundenwerte morgens (7:00 - 8:00)

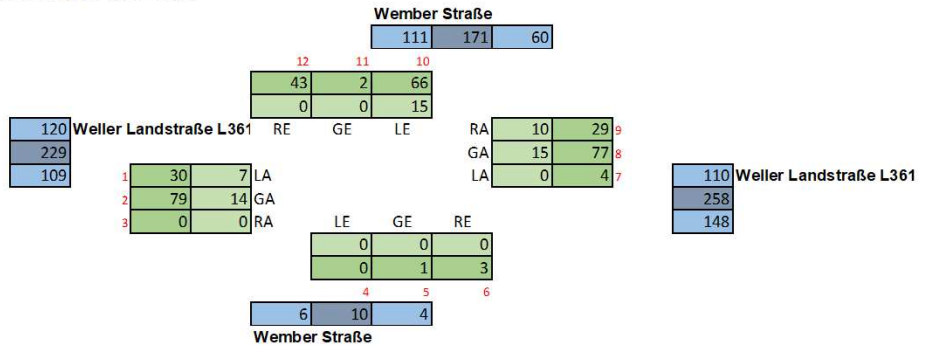
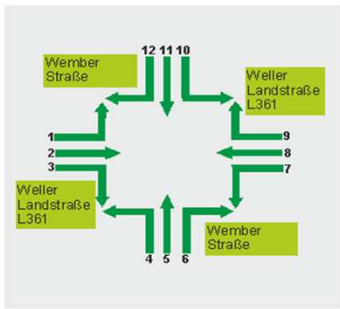

Graphische Darstellung der Spitzenstundenwerte nachmittags (17:00 - 18:00)

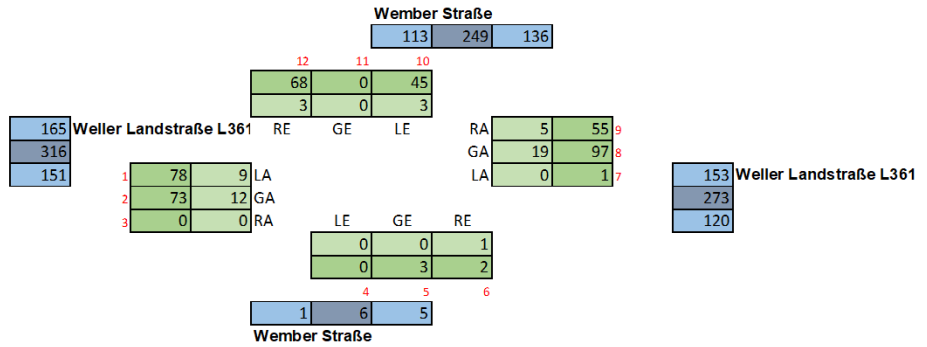

- Legende**
- Kfz/Spitzenstunde
 - Lkw/Spitzenstunde (inklusive Lieferverkehr)
 - Kfz/Spitzenstunde gesamt
 - Kfz/Spitzenstunde richtungsbezogen

Knotenpunkt 9

Wember Straße/Hüls/Wember Straße/Heideweg

Intervall	Fz-Arten	Wember Straße			Hüls			Wember Straße			Heideweg		
		LA	GA	RA	LE	GE	RE	LA	GE	RA	LE	GE	RE
		1	2	3	4	5	6	7	8	9	10	11	12
Hochrechnung DTV													
Summe Kfz/4h (6-10)		28	161	26	27	19	98	110	286	33	53	40	47
Summe Pkw/4h (6-10)		10	149	22	22	12	80	84	259	19	44	34	26
Summe Lkw/4h (6-10)		18	12	4	5	7	18	26	27	14	9	6	21
Summe Kfz/4h (15-19)		55	407	48	34	71	141	136	370	71	78	68	43
Summe Pkw/4h (15-19)		44	377	44	32	62	124	127	349	62	61	62	35
Summe Lkw/4h (15-19)		11	30	4	2	9	17	9	21	9	17	6	8
DTV 24 Stunden		1	2	3	4	5	6	7	8	9	10	11	12
Morgens Kfz	21%	131	752	121	126	89	458	514	1336	154	248	187	220
Morgens Lkw	30%	60	40	13	17	23	60	86	90	47	30	20	70
Nachmittags Kfz	33%	164	1217	144	102	212	422	407	1106	212	233	203	129
Nachmittags Lkw	27%	41	113	15	8	34	64	34	79	34	64	23	30
Mittelwert aus mo und na		148	985	132	114	151	440	460	1221	183	240	195	174
Lkw-Anteil mit Lieferverkehr		51	76	14	12	29	62	60	84	40	47	21	50
Lkw-Anteil mit Lieferverkehr in %		34%	8%	11%	11%	19%	14%	13%	7%	22%	20%	11%	29%
davon mo	PKW	10	148	22	22	11	78	81	256	18	44	31	26
	KRAD	0	1	0	0	1	2	3	3	1	0	3	0
	LIEFERWAGEN	3	6	0	4	3	8	22	18	10	8	6	4
	LKW	15	6	4	1	4	10	4	9	4	1	0	17
davon	PKW	44	373	44	32	61	120	127	346	61	59	61	35
	KRAD	0	4	0	0	1	4	0	3	1	2	1	0
	LIEFERWAGEN	9	24	2	2	8	14	6	20	7	12	6	6
	LKW	2	6	2	0	1	3	3	1	2	5	0	2

Graphische Darstellung der DTV-Werte (Mittelwert aus mo und na):

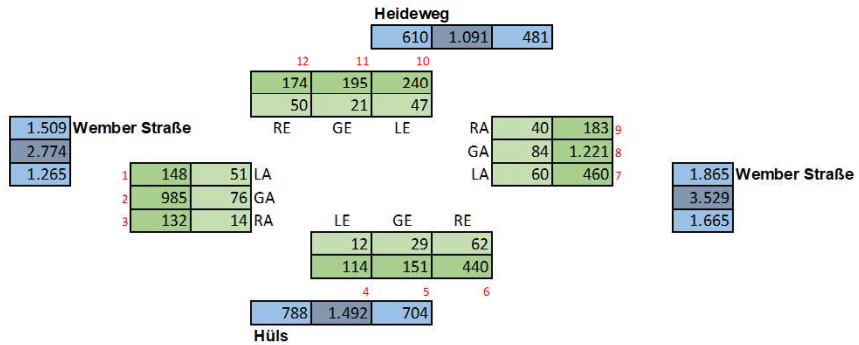
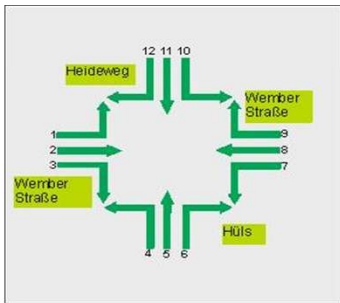

- Legende**
- DTV in Kfz/24h
 - Lkw in Kfz/24h (inklusive Lieferverkehr)
 - Gesamt DTV in beiden Richtungen
 - richtungsbezogener DTV

Graphische Darstellung der Spitzenstundenwerte morgens (7:00 - 8:00)

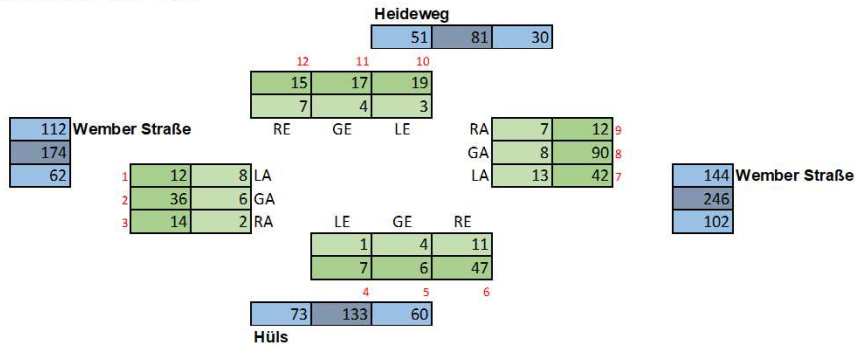
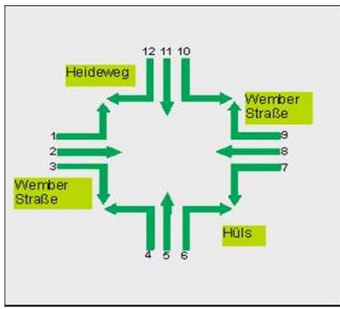

Graphische Darstellung der Spitzenstundenwerte nachmittags (17:00 - 18:00)

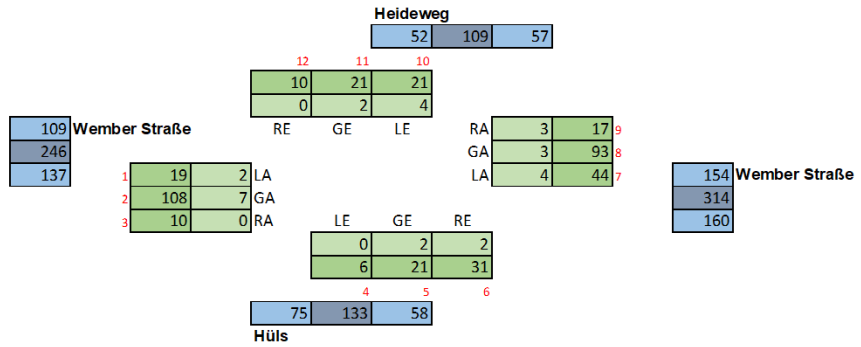

Legende

- Kfz/Spitzenstunde
- Lkw/Spitzenstunde (inklusive Lieferverkehr)
- Kfz/Spitzenstunde gesamt
- Kfz/Spitzenstunde richtungsbezogen

Knotenpunkt 10

Twistedener Straße/Walbecker Straße/Kroatensstraße

September 2019

2 mal 4 Stunden-Zählung

Datum der Zählung: Do. 17.09.2019

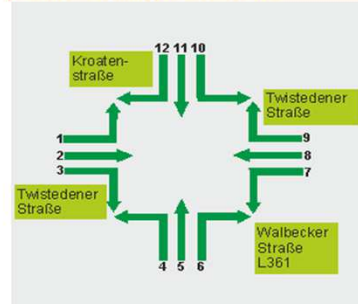

Intervall	Fz-Arten	Twistedener Straße			Walbecker Straße			Twistedener Straße			Kroatensstraße		
		LA	GA	RA	LE	GE	RE	LA	GE	RA	LE	GE	RE
		1	2	3	4	5	6	7	8	9	10	11	12
06:00 - 06:15	PKW	1	4	0	0	8	1	4	3	1	3	5	1
	KRAD	0	0	0	0	0	1	0	0	0	0	1	0
	LIEFERWAGEN	0	0	1	1	1	0	1	0	1	0	2	0
	LKW	0	0	0	0	1	0	0	0	0	0	0	0
06:15 - 06:30	PKW	0	1	1	1	7	2	5	4	2	1	25	0
	KRAD	0	0	0	0	0	0	0	0	0	0	0	0
	LIEFERWAGEN	0	0	0	0	1	0	1	0	1	0	2	0
	LKW	0	0	0	0	0	0	0	0	0	0	0	0
06:30 - 06:45	PKW	3	5	0	3	15	1	4	4	2	0	25	1
	KRAD	0	0	0	0	0	0	0	0	0	0	1	0
	LIEFERWAGEN	2	2	0	0	2	0	2	1	0	0	4	0
	LKW	0	2	0	0	2	0	0	0	0	0	0	0
06:45 - 07:00	PKW	5	9	2	0	19	7	3	5	2	6	21	5
	KRAD	0	0	0	0	0	0	0	0	0	0	0	0
	LIEFERWAGEN	1	0	0	1	10	0	1	3	1	0	1	0
	LKW	0	1	0	0	0	0	0	2	0	0	0	0
07:00 - 07:15	PKW	4	12	2	3	24	5	7	7	4	3	25	3
	KRAD	0	2	0	0	0	0	0	0	0	0	2	0
	LIEFERWAGEN	1	3	3	0	7	0	1	0	1	2	5	1
	LKW	0	0	0	0	0	0	0	0	0	0	1	0
07:15 - 07:30	PKW	9	6	2	11	39	5	7	7	6	8	31	2
	KRAD	0	0	0	0	0	0	1	0	0	1	0	0
	LIEFERWAGEN	0	1	1	0	8	2	1	3	0	0	4	2
	LKW	0	0	0	0	0	1	2	0	0	0	1	1
07:30 - 07:45	PKW	7	20	13	12	46	7	5	15	11	12	41	8
	KRAD	0	0	1	0	1	1	0	2	0	0	0	1
	LIEFERWAGEN	0	2	3	1	2	0	2	0	0	1	4	0
	LKW	0	2	0	1	0	1	0	0	0	1	0	0
07:45 - 08:00	PKW	10	21	8	9	28	15	8	12	7	21	39	5
	KRAD	0	1	0	1	0	0	0	0	0	0	0	0
	LIEFERWAGEN	1	1	2	2	5	0	2	0	0	2	4	1
	LKW	0	1	0	0	0	0	0	2	0	0	0	0
08:00 - 08:15	PKW	7	14	8	5	29	12	3	15	10	10	20	6
	KRAD	0	1	0	0	0	0	0	0	0	0	0	0
	LIEFERWAGEN	0	2	0	1	4	5	1	1	0	0	5	1
	LKW	0	0	0	0	0	0	0	0	0	1	0	0
08:15 - 08:30	PKW	7	15	4	8	25	12	4	9	4	6	23	5
	KRAD	0	0	0	0	0	0	0	0	0	0	0	0
	LIEFERWAGEN	0	0	0	1	3	5	0	2	3	0	3	1
	LKW	0	0	0	0	0	0	0	0	0	1	1	0
08:30 - 08:45	PKW	9	14	7	3	21	19	10	10	7	7	18	4
	KRAD	0	0	0	0	0	0	0	0	0	0	0	0
	LIEFERWAGEN	1	2	0	2	3	1	0	5	1	0	0	0
	LKW	0	1	0	1	0	0	0	0	0	0	0	0
08:45 - 09:00	PKW	13	16	7	9	29	8	9	8	8	8	25	2
	KRAD	0	0	0	0	0	0	0	0	0	2	0	0
	LIEFERWAGEN	0	0	2	1	4	0	2	0	1	3	2	0
	LKW	0	0	1	0	0	1	0	1	1	0	0	0
09:00 - 09:15	PKW	8	15	3	1	25	12	10	6	5	9	17	1
	KRAD	0	0	0	0	0	0	0	0	0	0	1	0
	LIEFERWAGEN	1	0	0	1	2	0	1	3	0	0	2	0
	LKW	0	0	0	0	1	0	0	0	0	0	2	0
09:15 - 09:30	PKW	5	15	1	4	13	23	13	7	9	8	24	3
	KRAD	0	0	0	0	0	0	0	0	0	1	0	0
	LIEFERWAGEN	0	1	0	1	5	3	0	3	0	1	3	0
	LKW	0	0	0	0	0	1	0	0	1	0	0	0
09:30 - 09:45	PKW	8	12	2	5	26	15	5	10	6	11	24	2
	KRAD	0	0	0	0	0	0	0	0	0	0	0	0
	LIEFERWAGEN	0	3	2	1	3	0	3	6	5	0	0	1
	LKW	0	1	0	0	0	1	0	0	1	0	0	0
09:45 - 10:00	PKW	6	13	3	4	17	12	9	14	4	11	16	8
	KRAD	0	0	0	0	0	1	0	0	0	1	0	0
	LIEFERWAGEN	1	1	1	0	0	0	6	3	3	0	3	0
	LKW	0	0	0	0	0	0	0	1	0	0	0	0

Intervall	Fz-Arten	Twistedener Straße			Walbecker Straße			Twistedener Straße			Kroatenstraße		
		LA	GA	RA	LE	GE	RE	LA	GE	RA	LE	GE	RE
		1	2	3	4	5	6	7	8	9	10	11	12
15:00 - 15:15	PKW	5	13	6	8	42	12	17	22	9	14	21	3
	KRAD	0	0	0	0	0	1	0	1	1	0	1	0
	LIEFERWAGEN	3	0	1	1	1	0	1	3	0	0	2	0
	LKW	0	0	0	0	0	0	1	0	0	0	1	0
15:15 - 15:30	PKW	12	16	6	4	27	18	20	18	10	10	34	8
	KRAD	1	0	1	0	0	0	1	0	0	0	0	0
	LIEFERWAGEN	1	0	0	0	4	0	0	2	3	1	0	1
	LKW	0	0	0	1	0	0	0	0	0	0	0	0
15:30 - 15:45	PKW	7	26	6	3	48	12	9	16	13	4	22	3
	KRAD	0	0	1	0	0	0	1	1	1	1	0	0
	LIEFERWAGEN	1	1	1	1	3	1	0	2	1	1	2	0
	LKW	1	1	0	1	0	0	0	0	0	0	0	0
15:45 - 16:00	PKW	8	24	14	21	36	17	18	12	19	15	24	7
	KRAD	1	0	0	0	0	1	0	2	0	0	0	0
	LIEFERWAGEN	2	0	2	0	3	1	3	0	0	1	2	0
	LKW	0	0	0	0	0	0	0	1	0	0	0	0
16:00 - 16:15	PKW	9	17	12	7	39	13	19	16	15	16	35	6
	KRAD	1	1	0	0	0	0	0	0	1	1	2	0
	LIEFERWAGEN	4	4	0	0	11	0	2	0	3	1	4	0
	LKW	0	0	0	0	2	1	0	0	0	0	0	0
16:15 - 16:30	PKW	7	10	9	10	38	18	16	16	12	10	39	3
	KRAD	0	0	0	0	0	0	0	0	0	0	0	0
	LIEFERWAGEN	0	2	0	0	5	3	1	2	1	0	1	0
	LKW	0	0	0	0	0	0	0	0	0	0	0	0
16:30 - 16:45	PKW	6	14	11	10	51	12	21	13	15	12	36	5
	KRAD	0	1	0	0	0	0	0	0	0	0	0	0
	LIEFERWAGEN	2	1	1	0	8	2	0	2	3	0	2	1
	LKW	0	1	0	0	0	0	1	0	0	0	0	0
16:45 - 17:00	PKW	5	12	11	6	47	14	27	21	7	16	30	5
	KRAD	1	0	0	0	0	1	0	0	0	0	0	1
	LIEFERWAGEN	0	2	1	2	7	2	3	1	0	0	5	1
	LKW	0	0	0	0	0	0	0	1	0	0	1	0
17:00 - 17:15	PKW	8	13	14	13	53	17	26	12	17	6	43	5
	KRAD	0	0	0	0	0	0	0	0	2	0	1	0
	LIEFERWAGEN	2	0	0	0	1	1	1	0	2	2	4	1
	LKW	0	0	0	0	0	0	0	0	0	0	0	0
17:15 - 17:30	PKW	6	19	7	7	55	23	29	16	11	10	41	2
	KRAD	1	2	0	0	4	0	2	1	0	0	0	0
	LIEFERWAGEN	1	2	2	1	4	0	1	4	0	1	2	0
	LKW m.A.	0	0	0	0	0	0	1	0	0	0	0	0
17:30 - 17:45	PKW	6	22	9	9	55	17	17	14	15	9	54	4
	KRAD	0	0	0	0	0	0	0	0	0	0	1	0
	LIEFERWAGEN	1	4	1	2	4	4	1	3	0	1	4	0
	LKW	0	1	0	0	0	0	1	0	0	0	0	0
17:45 - 18:00	PKW	8	12	11	7	60	17	14	22	12	7	38	4
	KRAD	0	0	0	0	0	0	0	0	0	0	0	0
	LIEFERWAGEN	1	1	0	1	4	0	1	0	1	1	6	0
	LKW	0	0	0	0	0	0	0	1	0	0	0	0
18:00 - 18:15	PKW	5	17	3	5	44	16	29	19	19	9	35	7
	KRAD	0	0	1	0	1	0	1	2	0	0	1	0
	LIEFERWAGEN	0	0	0	1	2	1	1	2	2	5	2	2
	LKW	0	0	0	0	0	0	0	1	0	0	0	0
18:15 - 18:30	PKW	5	18	10	5	31	13	17	19	13	4	27	5
	KRAD	0	1	0	0	0	0	1	0	0	0	0	0
	LIEFERWAGEN	1	2	0	0	5	0	1	2	2	1	4	0
	LKW	0	0	0	0	0	0	0	0	0	0	0	0
18:30 - 18:45	PKW	3	15	9	10	32	11	19	16	12	9	28	5
	KRAD	0	1	0	0	0	0	0	4	0	0	0	0
	LIEFERWAGEN	0	2	0	0	3	1	2	1	0	2	3	1
	LKW	0	1	0	0	0	0	0	0	0	0	0	0
18:45 - 19:00	PKW	6	14	4	8	29	12	12	17	9	9	20	3
	KRAD	0	1	0	0	0	0	1	0	0	0	0	0
	LIEFERWAGEN	0	0	0	0	3	0	0	2	1	1	3	1
	LKW	0	0	0	0	0	0	0	1	0	0	0	0

Knotenpunkt 10

Twistedener Straße/Walbecker Straße/Kroatenstraße

Intervall	Fz-Arten	Twistedener Straße			Walbecker Straße			Twistedener Straße			Kroatenstraße		
		LA	GA	RA	LE	GE	RE	LA	GE	RA	LE	GE	RE
		1	2	3	4	5	6	7	8	9	10	11	12
Hochrechnung DTV													
Summe Kfz/4h (6-10)		110	222	80	94	436	180	133	174	107	142	433	65
Summe Pkw/4h (6-10)		102	196	64	79	372	159	107	138	88	129	384	57
Summe Lkw/4h (6-10)		8	26	16	15	64	21	26	36	19	13	49	8
Summe Kfz/4h (15-19)		131	294	154	144	762	262	339	311	232	180	581	84
Summe Pkw/4h (15-19)		111	269	145	133	692	245	317	280	213	162	533	76
Summe Lkw/4h (15-19)		20	25	9	11	70	17	21	31	19	18	48	8
DTV 24 Stunden		1	2	3	4	5	6	7	8	9	10	11	12
Morgens Kfz	21%	514	1037	374	439	2037	841	621	813	500	663	2023	304
Morgens Lkw	30%	27	86	53	50	213	70	86	120	63	43	163	27
Nachmittags Kfz	33%	392	879	460	431	2278	783	1013	930	694	538	1737	251
Nachmittags Lkw	27%	75	94	34	41	264	64	79	117	72	68	181	30
Mittelwert aus mo und na		453	958	417	435	2158	812	817	871	597	601	1880	277
Lkw-Anteil mit Lieferverkehr		51	90	44	46	238	67	83	118	67	56	172	28
Lkw-Anteil mit Lieferverkehr in %		11%	9%	10%	10%	11%	8%	10%	14%	11%	9%	9%	10%
davon mo	PKW	102	192	63	78	371	156	106	136	88	124	379	56
	KRAD	0	4	1	1	1	3	1	2	0	5	5	1
	LIEFERWAGEN	8	18	15	13	60	16	24	30	17	9	44	7
	LKW	0	8	1	2	4	5	2	6	2	4	5	1
davon	PKW	106	262	142	133	687	242	310	269	208	160	527	75
	KRAD	5	7	3	0	5	3	7	11	5	2	6	1
	LIEFERWAGEN	19	21	9	9	68	16	18	26	19	18	46	8
	LKW	1	4	0	2	2	1	3	5	0	0	2	0

Graphische Darstellung der DTV-Werte (Mittelwert aus mo und na):

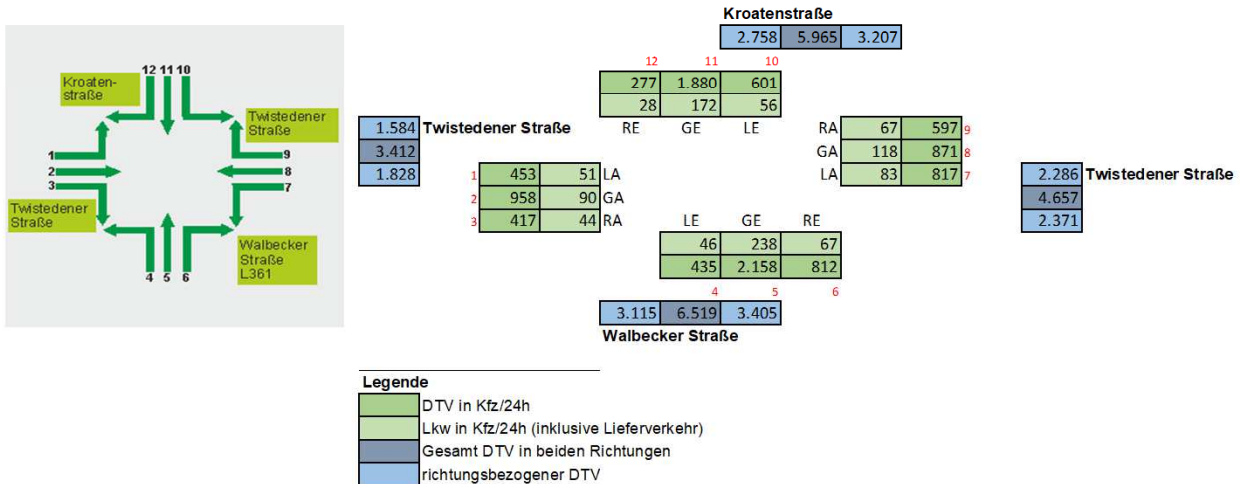

Graphische Darstellung der Spitzenstundenwerte morgens (7:00 - 8:00)

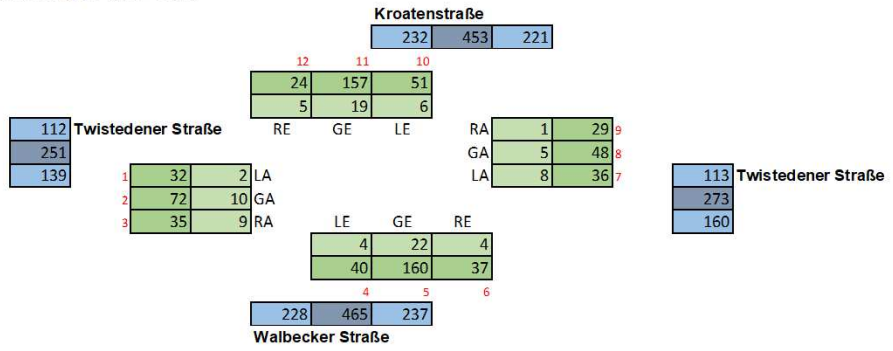
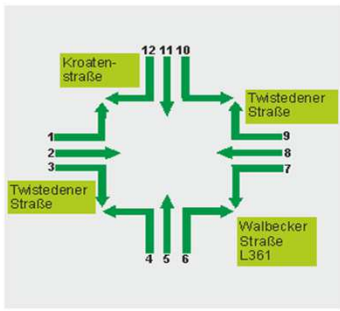

Graphische Darstellung der Spitzenstundenwerte nachmittags (17:00 - 18:00)

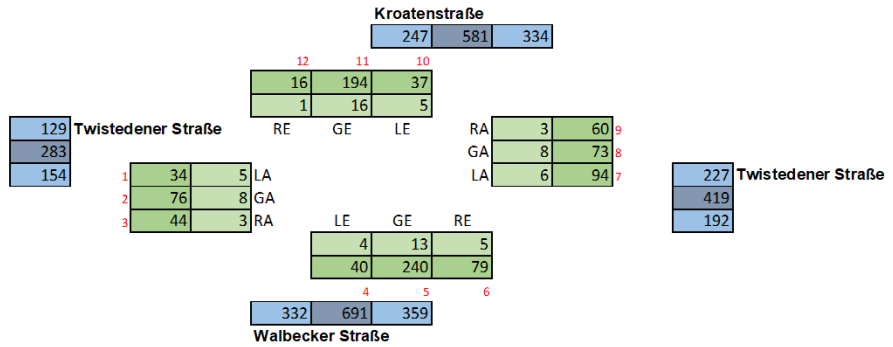

- Legende**
- Kfz/Spitzenstunde
 - Lkw/Spitzenstunde (inklusive Lieferverkehr)
 - Kfz/Spitzenstunde gesamt
 - Kfz/Spitzenstunde richtungsbezogen

Knotenpunkt 11

Twistedener Straße/Römerstraße/Marktstraße/Venloer Straße

September 2019

2 mal 4 Stunden-Zählung

Datum der Zählung: Do. 17.09.2019

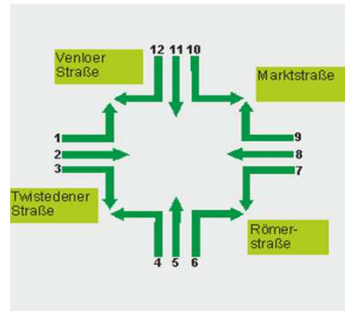

Intervall	Fz-Arten	Twistedener Straße			Römerstraße			Marktstraße			Venloer Straße		
		LA	GA	RA	LE	GE	RE	LA	GE	RA	LE	GE	RE
		1	2	3	4	5	6	7	8	9	10	11	12
06:00 - 06:15	PKW	3	10	0	0	1	0	1	7	1	2	0	1
	KRAD	0	0	0	0	0	0	0	0	0	0	0	0
	LIEFERWAGEN	0	0	0	0	0	0	0	0	0	0	0	1
	LKW	0	0	0	0	0	0	0	0	0	0	0	0
06:15 - 06:30	PKW	4	5	0	0	1	1	0	6	1	3	2	3
	KRAD	0	0	0	0	0	0	0	0	0	0	0	0
	LIEFERWAGEN	0	1	0	0	0	1	0	3	0	0	0	0
	LKW	0	0	0	0	0	0	0	0	0	0	0	0
06:30 - 06:45	PKW	4	5	0	0	3	1	1	10	2	9	0	2
	KRAD	0	0	0	0	0	0	0	0	0	0	0	0
	LIEFERWAGEN	0	2	0	0	0	0	0	2	1	0	0	1
	LKW	0	1	0	0	0	0	0	0	0	0	0	0
06:45 - 07:00	PKW	9	18	1	1	1	1	12	5	5	5	1	0
	KRAD	0	0	0	0	0	0	0	0	0	0	0	0
	LIEFERWAGEN	0	0	0	0	0	0	0	4	3	2	0	0
	LKW	0	1	0	0	0	0	0	1	0	0	0	1
07:00 - 07:15	PKW	12	12	2	0	1	1	1	16	6	14	5	4
	KRAD	0	2	0	0	0	0	0	0	0	0	0	0
	LIEFERWAGEN	1	3	0	0	0	0	0	1	1	1	0	0
	LKW	0	0	0	0	0	0	0	1	1	0	0	0
07:15 - 07:30	PKW	9	20	2	1	2	0	1	17	5	10	1	3
	KRAD	0	1	0	0	0	0	0	1	0	0	0	0
	LIEFERWAGEN	1	4	0	0	0	0	0	7	1	1	1	0
	LKW	1	0	0	0	0	0	0	2	0	0	0	0
07:30 - 07:45	PKW	15	30	3	0	1	0	6	33	11	8	0	9
	KRAD	0	1	0	0	0	0	0	3	0	1	0	0
	LIEFERWAGEN	2	2	0	0	0	0	1	2	1	4	0	0
	LKW	0	3	1	0	0	1	0	0	0	0	0	0
07:45 - 08:00	PKW	21	37	8	1	2	2	2	26	15	14	3	13
	KRAD	0	0	0	0	0	0	0	0	0	0	0	0
	LIEFERWAGEN	1	3	0	0	1	1	1	3	5	0	0	0
	LKW	0	0	0	0	0	0	0	2	0	0	0	0
08:00 - 08:15	PKW	14	42	1	0	0	0	0	15	17	11	1	10
	KRAD	0	2	0	0	0	0	0	0	0	0	0	0
	LIEFERWAGEN	1	4	0	0	0	0	0	3	1	1	0	0
	LKW	0	0	0	0	0	0	0	0	0	0	0	0
08:15 - 08:30	PKW	15	28	1	0	1	0	1	15	16	6	3	4
	KRAD	0	0	0	0	0	0	0	0	0	0	0	0
	LIEFERWAGEN	0	5	0	0	0	0	0	2	3	0	1	1
	LKW	0	0	0	0	0	0	0	0	0	0	0	0
08:30 - 08:45	PKW	12	32	1	3	2	1	1	28	8	14	5	4
	KRAD	0	0	0	0	0	0	0	0	0	0	0	0
	LIEFERWAGEN	1	3	0	2	2	0	1	6	0	0	0	0
	LKW	0	1	0	0	0	0	0	0	0	0	0	0
08:45 - 09:00	PKW	15	34	3	1	0	0	2	27	19	15	3	4
	KRAD	0	1	0	0	0	0	0	0	0	0	0	0
	LIEFERWAGEN	1	0	0	0	0	0	1	4	0	3	1	0
	LKW	0	0	0	0	0	0	0	2	0	0	0	0
09:00 - 09:15	PKW	8	33	0	1	1	0	4	27	17	23	2	7
	KRAD	0	0	0	0	0	0	0	0	0	1	0	1
	LIEFERWAGEN	1	1	1	0	0	0	0	3	0	1	1	0
	LKW	0	0	0	0	0	0	0	0	0	0	0	0
09:15 - 09:30	PKW	11	36	1	1	2	1	6	19	18	9	3	11
	KRAD	0	1	0	0	0	0	0	0	0	0	0	0
	LIEFERWAGEN	2	3	0	0	0	0	0	4	2	0	0	0
	LKW	0	2	0	0	0	0	0	0	0	0	0	0
09:30 - 09:45	PKW	6	36	3	1	2	2	1	27	20	17	3	4
	KRAD	0	0	0	0	0	0	0	0	0	0	0	0
	LIEFERWAGEN	0	2	0	1	0	0	0	10	4	4	0	0
	LKW	0	2	0	0	0	0	0	1	0	0	0	0
09:45 - 10:00	PKW	6	36	2	1	2	1	4	27	16	12	5	7
	KRAD	0	2	0	0	0	0	0	0	0	0	0	0
	LIEFERWAGEN	0	1	0	1	0	1	0	10	7	1	0	2
	LKW	0	0	0	0	0	0	0	1	0	0	0	0

Intervall	Fz-Arten	Twistedener Straße			Römerstraße			Marktstraße			Venloer Straße		
		LA	GA	RA	LE	GE	RE	LA	GE	RA	LE	GE	RE
		1	2	3	4	5	6	7	8	9	10	11	12
15:00 - 15:15	PKW	11	41	8	2	3	1	0	49	19	9	3	3
	KRAD	0	2	0	0	0	0	1	3	0	1	0	0
	LIEFERWAGEN	0	2	0	0	0	1	0	4	1	0	0	0
	LKW	0	0	0	0	0	0	0	1	0	0	0	0
15:15 - 15:30	PKW	6	34	1	1	1	3	2	51	20	16	1	7
	KRAD	0	0	0	0	0	0	1	0	0	0	0	1
	LIEFERWAGEN	0	1	1	0	0	0	0	6	7	3	0	1
	LKW	0	0	0	0	0	0	0	0	0	0	0	0
15:30 - 15:45	PKW	8	32	4	1	0	3	3	44	29	15	1	11
	KRAD	0	1	0	0	0	0	0	3	0	0	0	0
	LIEFERWAGEN	0	2	0	0	0	0	0	2	0	1	1	1
	LKW	0	1	0	0	0	0	0	0	0	0	0	0
15:45 - 16:00	PKW	14	40	3	4	2	2	4	44	16	9	2	11
	KRAD	0	2	0	0	2	0	2	0	0	0	0	0
	LIEFERWAGEN	0	4	0	0	0	0	0	2	1	2	0	1
	LKW	0	0	0	0	0	0	1	0	0	0	0	0
16:00 - 16:15	PKW	9	35	4	3	0	3	3	48	24	14	2	10
	KRAD	0	2	0	0	0	0	0	1	1	1	0	1
	LIEFERWAGEN	1	4	0	0	1	0	0	3	4	5	1	0
	LKW	0	1	0	0	0	0	0	0	0	0	0	0
16:15 - 16:30	PKW	9	26	3	0	1	2	4	48	31	16	3	11
	KRAD	0	0	0	0	0	0	0	0	1	0	0	0
	LIEFERWAGEN	0	5	0	0	0	0	1	3	1	0	0	0
	LKW	0	0	0	0	0	0	0	0	0	0	0	0
16:30 - 16:45	PKW	12	43	3	2	3	1	3	47	25	17	2	7
	KRAD	1	0	0	0	0	0	0	0	1	0	0	0
	LIEFERWAGEN	2	1	1	1	1	0	0	5	0	0	0	0
	LKW	0	1	0	0	0	0	0	1	0	0	0	0
16:45 - 17:00	PKW	10	35	1	2	4	2	8	54	25	25	3	13
	KRAD	0	1	0	0	0	0	0	0	0	1	0	0
	LIEFERWAGEN	3	2	0	0	0	0	0	5	3	1	0	0
	LKW	0	0	0	0	0	0	0	1	0	1	0	0
17:00 - 17:15	PKW	5	32	4	3	5	0	2	56	22	17	3	8
	KRAD	0	0	0	0	0	0	0	3	1	0	0	0
	LIEFERWAGEN	0	2	0	0	0	0	0	0	1	1	0	0
	LKW	0	0	0	0	0	0	0	0	0	0	0	0
17:15 - 17:30	PKW	16	32	6	1	1	1	2	56	29	25	2	13
	KRAD	0	2	0	0	0	0	0	4	1	0	0	0
	LIEFERWAGEN	0	0	0	0	0	0	0	6	3	1	0	1
	LKW m.A.	0	1	0	0	0	0	0	1	0	0	0	0
17:30 - 17:45	PKW	8	51	3	2	2	3	5	47	22	14	2	5
	KRAD	0	1	0	0	0	0	0	0	0	0	0	0
	LIEFERWAGEN	1	6	0	0	0	0	0	3	1	1	0	0
	LKW	0	1	0	0	0	0	0	1	0	0	0	0
17:45 - 18:00	PKW	13	27	4	7	5	2	4	52	29	16	3	16
	KRAD	0	0	0	0	0	0	0	1	1	0	0	0
	LIEFERWAGEN	1	1	1	0	0	0	0	4	1	1	0	0
	LKW	0	0	0	0	0	0	0	1	0	0	0	0
18:00 - 18:15	PKW	12	33	6	3	3	2	3	56	29	12	0	9
	KRAD	0	0	0	0	0	0	0	4	1	0	0	0
	LIEFERWAGEN	1	5	0	0	0	0	0	3	0	1	0	0
	LKW	0	0	0	0	0	0	0	1	0	0	0	0
18:15 - 18:30	PKW	19	26	2	0	4	2	3	52	27	8	2	7
	KRAD	0	1	0	0	1	0	0	1	1	0	0	1
	LIEFERWAGEN	1	1	0	0	0	0	0	3	3	0	0	1
	LKW	0	1	0	0	0	0	0	0	0	0	0	0
18:30 - 18:45	PKW	10	27	5	2	1	1	1	48	13	13	0	10
	KRAD	1	0	0	0	0	0	0	3	0	0	0	0
	LIEFERWAGEN	0	4	0	0	1	0	0	2	0	1	0	0
	LKW	0	1	0	0	0	0	0	0	0	0	0	0
18:45 - 19:00	PKW	7	32	4	4	0	1	3	39	18	9	4	5
	KRAD	0	0	1	0	0	0	0	0	1	0	1	0
	LIEFERWAGEN	0	2	0	0	0	0	2	2	1	0	0	0
	LKW	0	0	0	0	0	0	0	1	0	0	0	0

Knotenpunkt 11

Twistedener Straße/Römerstraße/Marktstraße/Venloer Straße

Intervall	Fz-Arten	Twistedener Straße			Römerstraße			Marktstraße			Venloer Straße		
		LA	GA	RA	LE	GE	RE	LA	GE	RA	LE	GE	RE
		1	2	3	4	5	6	7	8	9	10	11	12
Hochrechnung DTV													
Summe Kfz/4h (6-10)		176	468	30	15	24	15	36	390	207	192	41	93
Summe Pkw/4h (6-10)		164	424	28	11	21	11	32	316	177	174	37	87
Summe Lkw/4h (6-10)		12	44	2	4	3	4	4	74	30	18	4	6
Summe Kfz/4h (15-19)		181	607	65	38	41	30	54	879	414	257	36	154
Summe Pkw/4h (15-19)		171	558	62	37	38	29	51	817	387	238	34	149
Summe Lkw/4h (15-19)		10	48	3	1	3	1	3	61	27	19	2	5
DTV 24 Stunden		1	2	3	4	5	6	7	8	9	10	11	12
Morgens Kfz	21%	822	2187	140	70	112	70	168	1822	967	897	192	435
Morgens Lkw	30%	40	146	7	13	10	13	13	246	100	60	13	20
Nachmittags Kfz	33%	541	1815	194	114	123	90	161	2628	1238	768	108	460
Nachmittags Lkw	27%	38	181	11	4	11	4	11	230	102	72	8	19
Mittelwert aus mo und na		682	2001	167	92	117	80	165	2225	1102	833	150	447
Lkw-Anteil mit Lieferverkehr		39	164	9	9	11	9	12	238	101	66	10	19
Lkw-Anteil mit Lieferverkehr in %		6%	8%	5%	9%	9%	11%	7%	11%	9%	8%	7%	4%
davon mo	PKW	164	414	28	11	21	11	32	312	177	172	37	86
	KRAD	0	10	0	0	0	0	0	4	0	2	0	1
	LIEFERWAGEN	11	34	1	4	3	3	4	64	29	18	4	5
	LKW	1	10	1	0	0	1	0	10	1	0	0	1
davon	PKW	169	546	61	37	35	29	50	791	378	235	33	146
	KRAD	2	12	1	0	3	0	1	26	9	3	1	3
	LIEFERWAGEN	10	42	3	1	3	1	3	53	27	18	2	5
	LKW	0	6	0	0	0	0	0	8	0	1	0	0

Graphische Darstellung der DTV-Werte (Mittelwert aus mo und na):

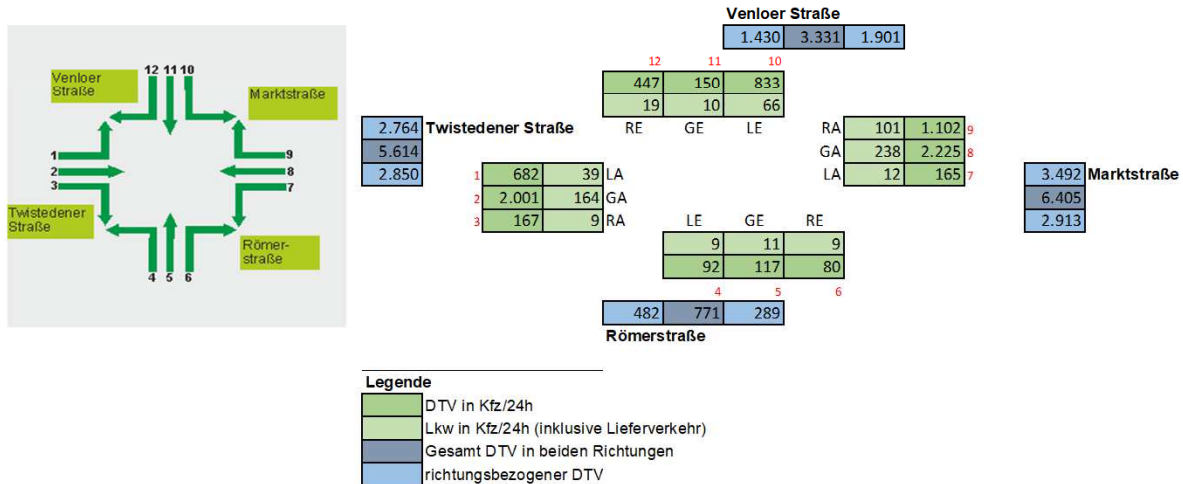

Graphische Darstellung der Spitzenstundenwerte morgens (7:00 - 8:00)

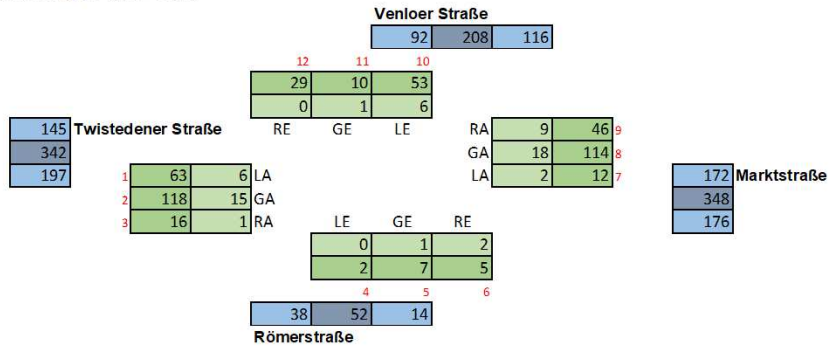
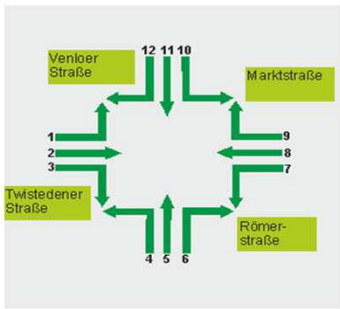

Graphische Darstellung der Spitzenstundenwerte nachmittags (17:00 - 18:00)

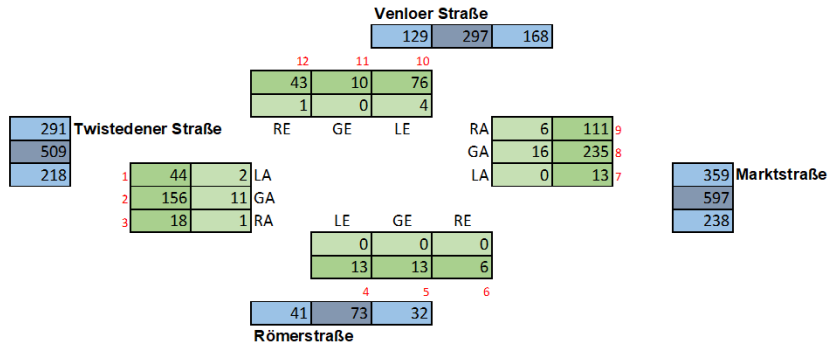

- Legende**
- Kfz/Spitzenstunde
 - Lkw/Spitzenstunde (inklusive Lieferverkehr)
 - Kfz/Spitzenstunde gesamt
 - Kfz/Spitzenstunde richtungsbezogen

Knotenpunkt 12

Marktstraße/Geldener Straße/Bahnstraße/Hauptstraße

Intervall	Fz-Arten	Marktstraße			Geldener Straße			Bahnstraße			Hauptstraße		
		LA	GA	RA	LE	GE	RE	LA	GE	RA	LE	GE	RE
		1	2	3	4	5	6	7	8	9	10	11	12
Hochrechnung DTV													
Summe Kfz/4h (6-10)		4	1	614	246	2	0	212	528	4	0	2	1
Summe Pkw/4h (6-10)		1	1	545	206	0	0	184	463	1	0	0	1
Summe Lkw/4h (6-10)		3	0	69	40	2	0	28	65	3	0	2	0
Summe Kfz/4h (15-19)		1	0	921	428	0	0	408	861	1	0	0	0
Summe Pkw/4h (15-19)		1	0	849	390	0	0	368	811	0	0	0	0
Summe Lkw/4h (15-19)		0	0	72	38	0	0	39	50	1	0	0	0
DTV 24 Stunden		1	2	3	4	5	6	7	8	9	10	11	12
Morgens Kfz	21%	19	5	2869	1149	9	0	991	2467	19	0	9	5
Morgens Lkw	30%	10	0	229	133	7	0	93	216	10	0	7	0
Nachmittags Kfz	33%	3	0	2753	1280	0	0	1220	2574	3	0	0	0
Nachmittags Lkw	27%	0	0	271	143	0	0	147	189	4	0	0	0
Mittelwert aus mo und na		11	2	2811	1214	5	0	1105	2520	11	0	5	2
Lkw-Anteil mit Lieferverkehr		5	0	250	138	3	0	120	202	7	0	3	0
Lkw-Anteil mit Lieferverkehr in %		46%	0%	9%	11%	71%	0%	11%	8%	63%	0%	71%	0%

davon mo	Fz-Arten	1	2	3	4	5	6	7	8	9	10	11	12
	PKW	1	0	532	206	0	0	184	457	1	0	0	1
	KRAD	0	1	13	0	0	0	0	6	0	0	0	0
	LIEFERWAGEN	2	0	45	29	1	0	17	55	1	0	1	0
	LKW	1	0	24	11	1	0	11	10	2	0	1	0

davon na	Fz-Arten	1	2	3	4	5	6	7	8	9	10	11	12
	PKW	0	0	833	385	0	0	359	789	0	0	0	0
	KRAD	1	0	16	5	0	0	9	22	0	0	0	0
	LIEFERWAGEN	0	0	61	27	0	0	35	45	1	0	0	0
	LKW	0	0	11	11	0	0	4	5	0	0	0	0

Graphische Darstellung der DTV-Werte (Mittelwert aus mo und na):

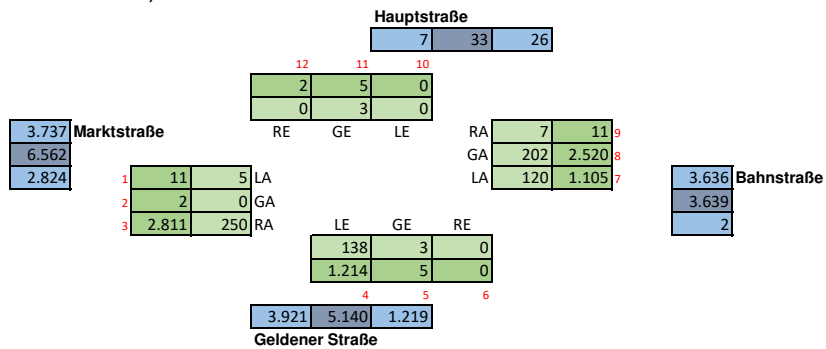
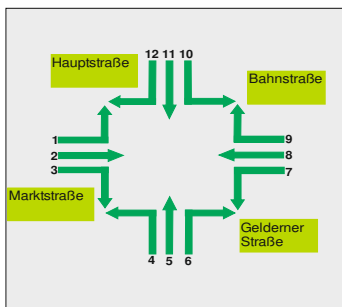

- Legende**
- DTV in Kfz/24h
 - Lkw in Kfz/24h (inklusive Lieferverkehr)
 - Gesamt DTV in beiden Richtungen
 - richtungsbezogener DTV

Graphische Darstellung der Spitzenstundenwerte morgens (7:00 - 8:00)

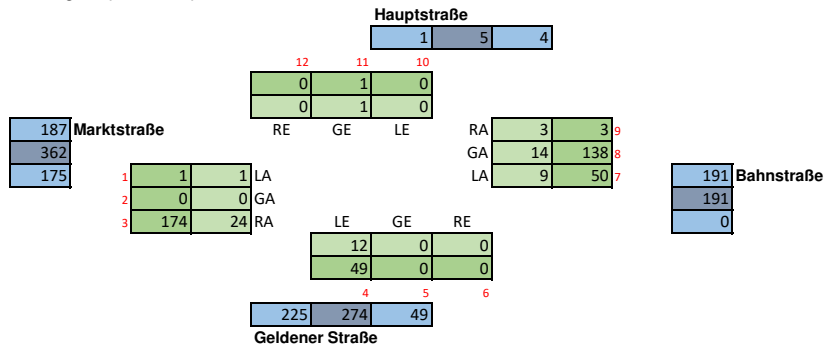
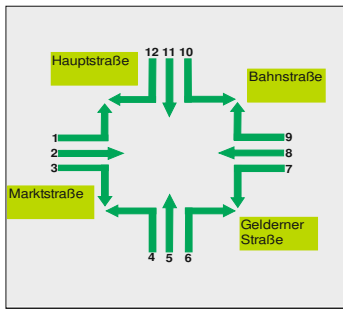

Graphische Darstellung der Spitzenstundenwerte nachmittags (17:00 - 18:00)

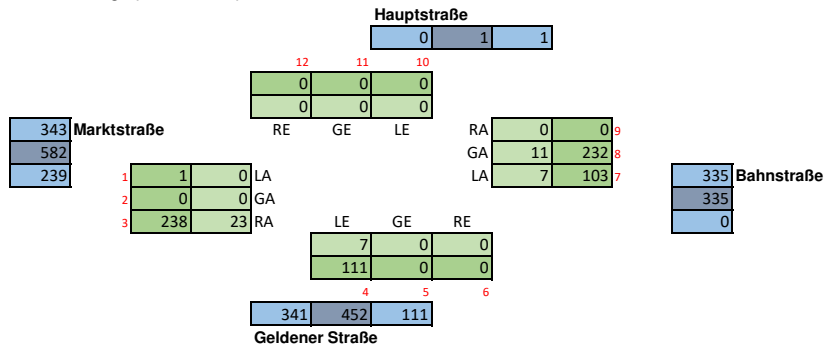

- Legende**
- Kfz/Spitzenstunde
 - Lkw/Spitzenstunde (inklusive Lieferverkehr)
 - Kfz/Spitzenstunde gesamt
 - Kfz/Spitzenstunde richtungsbezogen

Knotenpunkt 13

Wember Straße/Kroatenstraße/gmontstraße

September 2019

2 mal 4 Stunden-Zählung

Datum der Zählung: Do. 17.09.2019

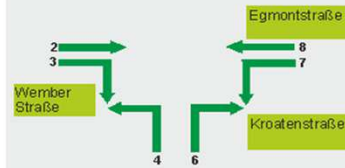

Intervall	Fz-Arten	Wember Straße		Kroatenstraße		Egmontstraße							
		GA	RA	LE	RE	LA	GE						
		2	3	4	6	7	8						
06:00 - 06:15	PKW	9	2	1	9	7	11						
	KRAD	0	1	0	0	0	0						
	LIEFERWAGEN	1	0	0	2	2	1						
	LKW	0	0	0	1	0	1						
06:15 - 06:30	PKW	18	1	0	11	23	18						
	KRAD	0	0	0	0	0	0						
	LIEFERWAGEN	0	0	1	1	3	4						
	LKW	0	0	0	0	0	0						
06:30 - 06:45	PKW	15	3	2	25	18	17						
	KRAD	1	1	0	0	0	2						
	LIEFERWAGEN	1	0	1	2	1	2						
	LKW	0	0	0	2	0	0						
06:45 - 07:00	PKW	14	3	4	29	17	19						
	KRAD	1	0	0	0	0	0						
	LIEFERWAGEN	3	0	0	6	1	4						
	LKW	0	0	0	0	0	0						
07:00 - 07:15	PKW	12	2	1	36	16	12						
	KRAD	0	0	0	0	1	0						
	LIEFERWAGEN	1	0	0	9	4	3						
	LKW	2	0	0	0	1	2						
07:15 - 07:30	PKW	33	6	5	45	36	28						
	KRAD	0	0	0	0	0	0						
	LIEFERWAGEN	7	1	2	4	6	2						
	LKW	0	1	0	0	0	5						
07:30 - 07:45	PKW	37	6	4	49	59	41						
	KRAD	1	0	0	0	0	3						
	LIEFERWAGEN	4	1	1	1	4	4						
	LKW	5	2	0	0	0	3						
07:45 - 08:00	PKW	40	7	3	56	55	35						
	KRAD	0	0	0	0	1	1						
	LIEFERWAGEN	1	2	2	6	5	6						
	LKW	3	0	0	1	0	1						
08:00 - 08:15	PKW	30	4	10	26	26	22						
	KRAD	0	0	0	0	0	0						
	LIEFERWAGEN	4	0	0	2	5	1						
	LKW	1	0	0	0	1	0						
08:15 - 08:30	PKW	21	5	3	39	19	20						
	KRAD	0	0	0	0	0	0						
	LIEFERWAGEN	2	0	1	2	2	4						
	LKW	0	1	0	0	1	1						
08:30 - 08:45	PKW	34	2	6	27	17	22						
	KRAD	0	0	0	1	0	0						
	LIEFERWAGEN	6	1	0	3	0	1						
	LKW	0	0	0	0	0	2						
08:45 - 09:00	PKW	21	7	3	44	24	16						
	KRAD	0	1	0	0	0	0						
	LIEFERWAGEN	4	0	0	4	2	4						
	LKW	2	0	0	0	0	3						
09:00 - 09:15	PKW	28	5	5	39	21	21						
	KRAD	0	1	0	0	0	0						
	LIEFERWAGEN	2	0	0	3	1	1						
	LKW	0	1	0	1	0	1						
09:15 - 09:30	PKW	24	4	3	28	22	23						
	KRAD	1	2	0	1	0	1						
	LIEFERWAGEN	3	2	1	3	2	2						
	LKW	1	0	0	0	0	2						
09:30 - 09:45	PKW	28	3	4	37	32	17						
	KRAD	0	0	0	0	0	0						
	LIEFERWAGEN	2	0	2	2	0	3						
	LKW	1	0	0	1	0	1						
09:45 - 10:00	PKW	14	5	2	23	21	24						
	KRAD	0	0	0	0	0	1						
	LIEFERWAGEN	1	0	1	3	1	4						
	LKW	0	0	0	0	0	0						

Intervall	Fz-Arten	Wember Straße		Kroatenstraße		Egmontstraße					
		GA	RA	LE	RE	LA	GE				
		2	3	4	6	7	8				
15:00 - 15:15	PKW	24	4	12	40	34	26				
	KRAD	0	0	0	0	1	0				
	LIEFERWAGEN	4	0	0	3	0	5				
	LKW	4	1	0	0	0	0				
15:15 - 15:30	PKW	35	14	6	48	35	38				
	KRAD	0	0	0	0	0	0				
	LIEFERWAGEN	3	1	2	4	2	3				
	LKW	1	0	0	2	0	0				
15:30 - 15:45	PKW	50	9	7	51	29	31				
	KRAD	0	1	0	1	0	0				
	LIEFERWAGEN	2	0	1	7	0	1				
	LKW	1	0	0	1	0	1				
15:45 - 16:00	PKW	31	9	17	55	28	41				
	KRAD	0	0	1	1	0	1				
	LIEFERWAGEN	5	2	0	3	3	1				
	LKW	2	0	0	0	1	0				
16:00 - 16:15	PKW	41	12	9	62	46	40				
	KRAD	1	0	0	0	2	1				
	LIEFERWAGEN	4	1	0	12	2	3				
	LKW	3	0	0	2	0	0				
16:15 - 16:30	PKW	32	10	13	45	42	32				
	KRAD	0	0	0	0	0	0				
	LIEFERWAGEN	2	1	1	3	4	2				
	LKW	0	0	0	0	0	1				
16:30 - 16:45	PKW	42	7	10	52	41	39				
	KRAD	3	0	0	0	0	0				
	LIEFERWAGEN	0	0	4	7	1	5				
	LKW	2	0	0	0	1	1				
16:45 - 17:00	PKW	39	9	7	57	39	44				
	KRAD	1	0	0	0	0	1				
	LIEFERWAGEN	8	1	1	5	4	2				
	LKW	0	0	0	0	0	0				
17:00 - 17:15	PKW	48	7	13	69	41	40				
	KRAD	0	2	2	1	0	0				
	LIEFERWAGEN	5	1	0	2	5	7				
	LKW	0	0	0	0	0	0				
17:15 - 17:30	PKW	32	8	9	54	38	39				
	KRAD	1	0	1	3	0	1				
	LIEFERWAGEN	5	0	1	3	4	1				
	LKW m.A.	0	0	0	0	0	0				
17:30 - 17:45	PKW	30	12	13	66	53	47				
	KRAD	0	0	0	0	1	0				
	LIEFERWAGEN	2	0	0	1	2	3				
	LKW	0	0	0	0	0	1				
17:45 - 18:00	PKW	25	6	10	64	37	40				
	KRAD	0	0	0	0	1	1				
	LIEFERWAGEN	2	2	1	4	3	2				
	LKW	0	0	0	0	0	0				
18:00 - 18:15	PKW	37	10	9	51	37	37				
	KRAD	1	0	0	0	1	0				
	LIEFERWAGEN	1	3	0	2	3	3				
	LKW	0	0	0	0	0	0				
18:15 - 18:30	PKW	41	4	9	35	31	39				
	KRAD	0	0	1	1	0	0				
	LIEFERWAGEN	1	2	2	5	2	1				
	LKW	0	0	0	0	0	1				
18:30 - 18:45	PKW	14	8	9	42	32	25				
	KRAD	0	0	0	0	1	0				
	LIEFERWAGEN	4	1	2	1	4	0				
	LKW	0	0	0	0	0	0				
18:45 - 19:00	PKW	29	6	10	46	27	33				
	KRAD	1	0	0	0	0	1				
	LIEFERWAGEN	2	0	1	2	2	2				
	LKW	0	0	0	0	0	0				

Knotenpunkt 13

Wember Straße/Kroatenstraße/gmontstraße

Intervall	Fz-Arten	Wember Straße			Kroatenstraße			Egmontstraße		
		LA	GA	RA	LE	RE	LA	GE		
Hochrechnung DTV			2	3	4		6	7	8	
Summe Kfz/4h (6-10)			439	83	68		584	457	422	
Summe Pkw/4h (6-10)			382	71	56		525	415	354	
Summe Lkw/4h (6-10)			57	12	12		59	42	68	
Summe Kfz/4h (15-19)			621	154	184		913	640	643	
Summe Pkw/4h (15-19)			558	138	168		844	597	597	
Summe Lkw/4h (15-19)			63	16	16		69	43	46	
DTV 24 Stunden			2	3	4		6	7	8	
Morgens Kfz 21%			2051	388	318		2729	2135	1972	
Morgens Lkw 30%			189	40	40		196	140	226	
Nachmittags Kfz 33%			1857	460	550		2730	1913	1922	
Nachmittags Lkw 27%			238	60	60		260	162	173	
Mittelwert aus mo und na			1954	424	434		2729	2024	1947	
Lkw-Anteil mit Lieferverkehr			213	50	50		228	151	200	
Lkw-Anteil mit Lieferverkehr in %			11%	12%	12%		8%	7%	10%	
davon mo	PKW		378	65	56		523	413	346	
	KRAD		4	6	0		2	2	8	
	LIEFERWAGEN		42	7	12		53	39	46	
	LKW		15	5	0		6	3	22	
davon	PKW		550	135	163		837	590	591	
	KRAD		8	3	5		7	7	6	
	LIEFERWAGEN		50	15	16		64	41	41	
	LKW		13	1	0		5	2	5	

Graphische Darstellung der DTV-Werte (Mittelwert aus mo und na):

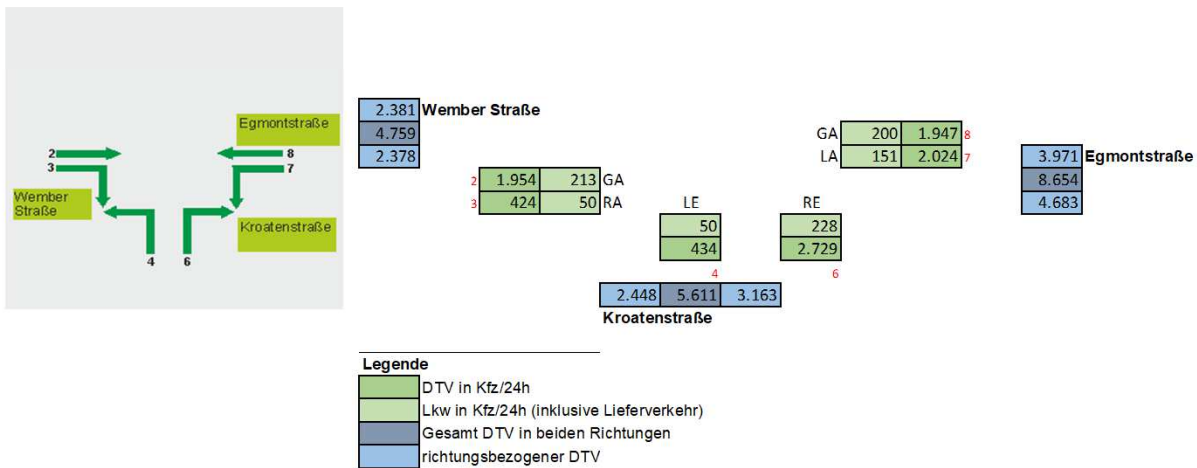

Graphische Darstellung der Spitzenstundenwerte morgens (7:00 - 8:00)

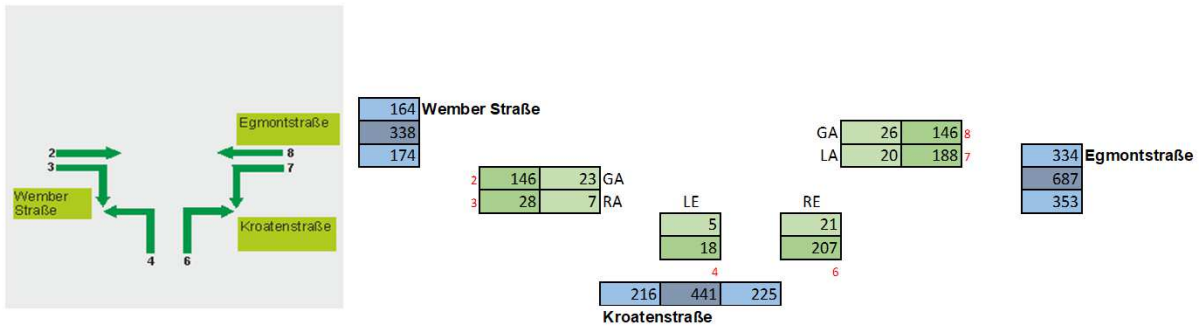

Graphische Darstellung der Spitzenstundenwerte nachmittags (17:00 - 18:00)

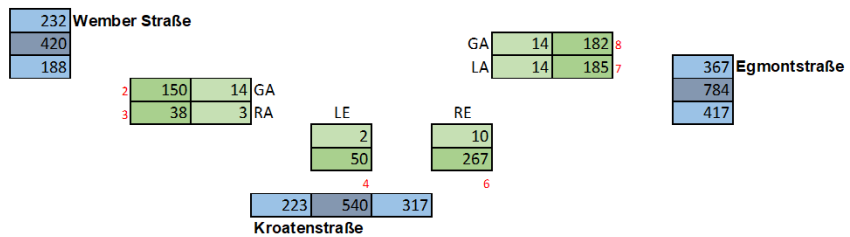

Knotenpunkt 14
 Klever Straße/Lindenstraße
 September 2019
 2 mal 4 Stunden-Zählung

Datum der Zählung: Do. 19.09.2019

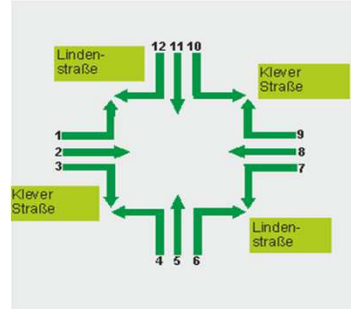

Intervall	Fz-Arten	Klever Straße (nordwestlich)			Lindenstraße (südwestlich)			Klever Straße (südöstlich)			Lindenstraße (nordöstlich)		
		LA	GA	RA	LE	GE	RE	LA	GE	RA	LE	GE	RE
		1	2	3	4	5	6	7	8	9	10	11	12
06:00 - 06:15	PKW	0	49	3	6	1	17	3	30	0	1	1	2
	KRAD	0	0	0	0	0	0	0	0	0	0	0	0
	LIEFERWAGEN	0	4	2	0	0	3	2	4	1	0	0	1
	LKW	0	18	0	1	0	1	1	4	0	0	0	0
06:15 - 06:30	PKW	1	64	7	19	4	31	10	25	2	2	3	1
	KRAD	0	0	0	0	0	0	0	0	0	0	0	0
	LIEFERWAGEN	0	6	7	1	0	1	2	7	1	0	0	1
	LKW	0	17	0	0	0	0	0	4	0	1	0	0
06:30 - 06:45	PKW	2	72	7	24	2	33	6	47	4	3	2	4
	KRAD	0	0	0	0	0	0	1	0	0	0	0	0
	LIEFERWAGEN	0	8	0	1	1	4	3	8	0	1	0	0
	LKW	0	13	0	0	0	8	0	8	1	0	1	0
06:45 - 07:00	PKW	6	61	13	27	1	34	9	62	20	2	3	5
	KRAD	0	0	0	0	0	0	0	0	0	0	0	0
	LIEFERWAGEN	1	15	4	2	3	3	1	5	2	1	0	0
	LKW	0	16	1	0	0	0	1	8	1	0	0	0
07:00 - 07:15	PKW	5	62	15	47	4	36	18	53	7	9	4	2
	KRAD	0	0	0	0	0	0	0	1	0	0	0	0
	LIEFERWAGEN	2	16	2	4	0	2	6	6	3	5	2	1
	LKW	0	15	1	1	0	1	0	6	0	1	2	1
07:15 - 07:30	PKW	1	88	16	46	9	61	38	70	7	9	6	10
	KRAD	0	2	0	0	0	0	0	0	0	0	0	0
	LIEFERWAGEN	0	16	5	4	2	5	4	6	0	2	2	4
	LKW	2	13	1	0	0	0	1	5	0	0	3	0
07:30 - 07:45	PKW	3	106	25	42	14	44	25	71	5	12	9	5
	KRAD	0	4	0	0	0	0	0	0	0	1	1	0
	LIEFERWAGEN	1	22	1	2	0	5	7	11	2	2	6	0
	LKW	1	16	1	0	0	3	1	9	1	1	0	0
07:45 - 08:00	PKW	2	113	35	44	7	41	29	50	12	8	12	4
	KRAD	0	0	0	1	0	0	0	0	0	0	1	0
	LIEFERWAGEN	0	17	5	4	0	5	5	13	2	1	2	2
	LKW	0	14	0	0	1	2	1	10	1	1	0	1
08:00 - 08:15	PKW	7	79	19	30	6	35	26	54	7	15	5	8
	KRAD	0	1	0	0	0	0	0	0	0	0	0	0
	LIEFERWAGEN	3	11	2	5	1	4	6	16	0	1	2	0
	LKW	0	14	0	0	0	1	1	9	1	4	0	0
08:15 - 08:30	PKW	4	74	22	31	16	42	30	51	7	7	5	4
	KRAD	0	0	0	0	0	0	0	0	0	0	0	0
	LIEFERWAGEN	3	11	11	2	0	6	6	17	2	1	2	1
	LKW	1	12	0	0	0	1	2	9	1	2	1	0
08:30 - 08:45	PKW	5	71	22	21	11	22	27	35	11	8	6	5
	KRAD	0	0	0	0	0	0	0	0	1	1	0	0
	LIEFERWAGEN	2	6	3	1	1	4	5	14	0	1	4	1
	LKW	1	11	1	0	1	0	2	9	2	1	0	1
08:45 - 09:00	PKW	5	65	18	25	18	40	33	41	12	6	6	4
	KRAD	0	0	0	0	0	1	1	0	1	0	0	0
	LIEFERWAGEN	0	0	3	3	1	5	1	11	1	0	1	1
	LKW	1	10	0	0	0	1	1	5	1	2	1	1
09:00 - 09:15	PKW	1	50	16	21	11	39	27	43	17	20	7	0
	KRAD	1	0	0	0	1	0	0	1	0	0	1	0
	LIEFERWAGEN	0	7	1	3	1	4	6	7	0	1	1	0
	LKW	0	12	1	0	0	1	1	13	0	1	0	2
09:15 - 09:30	PKW	6	39	17	19	11	38	28	35	16	12	9	7
	KRAD	0	0	0	0	1	0	0	0	0	0	0	0
	LIEFERWAGEN	1	6	1	2	2	1	3	4	2	0	2	2
	LKW	1	12	1	1	0	0	3	10	0	2	0	0
09:30 - 09:45	PKW	5	54	24	16	22	26	28	38	13	12	19	0
	KRAD	0	2	0	0	1	0	0	1	0	0	0	0
	LIEFERWAGEN	0	7	2	3	0	3	3	7	0	2	3	1
	LKW	0	8	1	0	0	3	2	13	1	0	0	0
09:45 - 10:00	PKW	4	59	22	19	21	34	30	54	17	15	21	8
	KRAD	0	0	0	0	1	0	0	0	1	0	1	0
	LIEFERWAGEN	0	7	0	4	1	4	1	11	2	3	1	0
	LKW	0	12	1	0	0	0	0	11	0	0	0	1

Intervall	Fz-Arten	ever Straße (nordwestlich)			indenstraße (südwestlich)			Klever Straße (südöstlich)			indenstraße (nordöstlich)		
		LA	GA	RA	LE	GE	RE	LA	GE	RA	LE	GE	RE
		1	2	3	4	5	6	7	8	9	10	11	12
15:00 - 15:15	PKW	6	68	25	31	16	34	40	65	9	16	20	5
	KRAD	0	1	0	0	1	0	0	0	0	0	0	0
	LIEFERWAGEN	1	6	4	7	2	4	1	7	1	1	0	2
	LKW	1	9	0	1	2	0	0	3	0	2	0	0
15:15 - 15:30	PKW	6	60	26	34	12	35	36	86	21	12	18	10
	KRAD	0	1	0	0	1	0	0	1	1	0	0	0
	LIEFERWAGEN	2	6	3	2	5	1	4	17	2	2	3	1
	LKW	0	12	0	1	1	0	2	11	0	0	0	2
15:30 - 15:45	PKW	5	63	34	27	13	40	30	67	21	14	14	11
	KRAD	0	1	0	0	0	0	0	1	1	0	0	0
	LIEFERWAGEN	0	7	0	5	2	2	4	22	7	2	3	1
	LKW	0	10	1	1	1	0	1	9	3	0	0	1
15:45 - 16:00	PKW	9	65	25	37	18	47	42	87	23	20	21	8
	KRAD	0	1	0	0	0	0	0	0	1	0	0	0
	LIEFERWAGEN	2	8	1	5	0	6	6	11	0	1	4	1
	LKW	1	5	0	1	1	3	1	14	3	1	0	1
16:00 - 16:15	PKW	6	73	32	39	17	48	30	75	17	20	17	18
	KRAD	0	1	2	0	1	0	1	0	1	0	0	0
	LIEFERWAGEN	1	18	4	5	2	9	3	7	3	1	4	1
	LKW	0	6	0	0	2	2	0	8	0	1	0	0
16:15 - 16:30	PKW	10	85	32	39	15	45	48	85	22	18	15	9
	KRAD	0	0	0	0	0	0	0	3	0	0	1	1
	LIEFERWAGEN	0	12	5	6	0	3	1	18	0	2	1	2
	LKW	0	8	0	0	0	1	2	13	0	1	0	1
16:30 - 16:45	PKW	9	83	34	48	10	41	34	87	17	23	32	12
	KRAD	0	0	2	0	0	1	0	1	0	1	0	0
	LIEFERWAGEN	0	15	2	7	0	5	6	15	3	3	2	0
	LKW	0	4	2	0	0	2	0	10	4	1	1	1
16:45 - 17:00	PKW	8	100	29	44	18	55	54	95	16	15	16	11
	KRAD	0	0	0	0	2	0	0	3	0	0	1	0
	LIEFERWAGEN	1	9	2	10	0	8	5	10	3	1	0	1
	LKW	0	3	0	0	0	0	0	4	0	1	0	0
17:00 - 17:15	PKW	11	82	24	31	12	42	38	106	22	19	16	17
	KRAD	0	0	0	0	1	0	0	1	0	0	0	0
	LIEFERWAGEN	1	6	0	2	1	4	5	15	4	4	4	0
	LKW	0	4	0	0	0	0	0	9	2	1	0	0
17:15 - 17:30	PKW	16	83	39	45	17	54	43	96	24	12	21	9
	KRAD	0	2	1	0	0	0	0	0	0	0	0	2
	LIEFERWAGEN	1	8	2	1	2	6	3	15	0	3	0	0
	LKW m.A.	0	4	0	0	0	0	1	6	0	0	0	0
17:30 - 17:45	PKW	11	78	35	33	12	46	47	80	25	16	26	22
	KRAD	0	0	0	0	0	0	0	0	0	0	0	0
	LIEFERWAGEN	0	6	1	5	2	1	1	4	0	2	0	0
	LKW	0	3	0	0	0	2	0	4	0	0	0	0
17:45 - 18:00	PKW	5	83	25	37	15	51	35	88	13	21	18	11
	KRAD	0	0	0	0	0	0	1	0	0	0	0	0
	LIEFERWAGEN	0	10	4	0	1	2	4	8	0	0	1	0
	LKW	0	2	0	0	0	1	0	5	0	0	0	0
18:00 - 18:15	PKW	6	76	24	35	14	57	44	82	12	17	27	15
	KRAD	0	0	0	0	0	0	0	3	0	0	1	0
	LIEFERWAGEN	1	4	1	2	1	4	2	6	2	1	2	2
	LKW	0	3	0	0	0	0	0	3	0	0	0	0
18:15 - 18:30	PKW	9	58	23	34	11	45	49	79	16	10	22	6
	KRAD	0	0	0	0	0	0	1	0	0	0	0	0
	LIEFERWAGEN	0	2	2	3	0	3	0	10	1	2	0	0
	LKW	0	4	0	0	0	0	0	4	0	0	0	0
18:30 - 18:45	PKW	1	61	18	18	9	47	37	52	13	12	11	11
	KRAD	0	0	0	0	0	0	1	0	0	0	0	0
	LIEFERWAGEN	2	5	0	1	0	3	4	7	2	3	0	1
	LKW	0	1	0	0	0	0	0	2	1	0	0	0
18:45 - 19:00	PKW	3	40	19	28	11	51	31	52	11	2	11	7
	KRAD	0	0	0	0	0	1	0	0	0	0	1	0
	LIEFERWAGEN	1	3	1	2	1	0	4	0	0	1	1	0
	LKW	0	1	0	0	0	0	0	1	0	0	0	0

Knotenpunkt 14

Klever Straße/Lindenstraße

Intervall	Fz-Arten	Klever Straße (nordwestlich)			Lindenstraße (südwestlich)			Klever Straße (südöstlich)			Lindenstraße (nordöstlich)		
		LA	GA	RA	LE	GE	RE	LA	GE	RA	LE	GE	RE
		1	2	3	4	5	6	7	8	9	10	11	12
Hochrechnung DTV													
Summe Kfz/4h (6-10)		78	1.487	339	482	177	655	447	1.042	188	180	158	91
Summe Pkw/4h (6-10)		58	1.115	281	438	162	574	369	762	160	143	122	69
Summe Lkw/4h (6-10)		20	372	58	44	15	81	78	280	28	37	36	22
Summe Kfz/4h (15-19)		136	1.369	484	627	252	812	702	1.573	327	285	335	203
Summe Pkw/4h (15-19)		121	1.165	449	560	226	740	642	1.295	286	248	309	185
Summe Lkw/4h (15-19)		15	200	35	67	26	72	59	272	41	37	26	18
DTV 24 Stunden		1	2	3	4	5	6	7	8	9	10	11	12
Morgens Kfz	21%	364	6948	1584	2252	827	3060	2088	4868	878	841	738	425
Morgens Lkw	30%	66	1236	193	146	50	269	259	930	93	123	120	73
Nachmittags Kfz	33%	407	4093	1447	1875	753	2428	2099	4703	978	852	1002	607
Nachmittags Lkw	27%	57	754	132	253	98	271	222	1026	155	140	98	68
Mittelwert aus mo und na		386	5520	1515	2063	790	2744	2094	4786	928	847	870	516
Lkw-Anteil mit Lieferverkehr		62	995	162	199	74	270	241	978	124	131	109	70
Lkw-Anteil mit Lieferverkehr in %		16%	18%	11%	10%	9%	0%	12%	20%	13%	0%	13%	14%
davon mo	PKW	57	1.106	281	437	158	573	367	759	157	141	118	69
	KRAD	1	9	0	1	4	1	2	3	3	2	4	0
	LIEFERWAGEN	13	159	49	41	13	59	61	147	18	21	28	15
	LKW	7	213	9	3	2	22	17	133	10	16	8	7
davon	PKW	121	1.158	444	560	220	738	638	1.282	282	247	305	182
	KRAD	0	7	5	0	6	2	4	13	4	1	4	3
	LIEFERWAGEN	13	125	32	63	19	61	53	172	28	29	25	12
	LKW	2	75	3	4	7	11	6	100	13	8	1	6

Graphische Darstellung der DTV-Werte (Mittelwert aus mo und na):

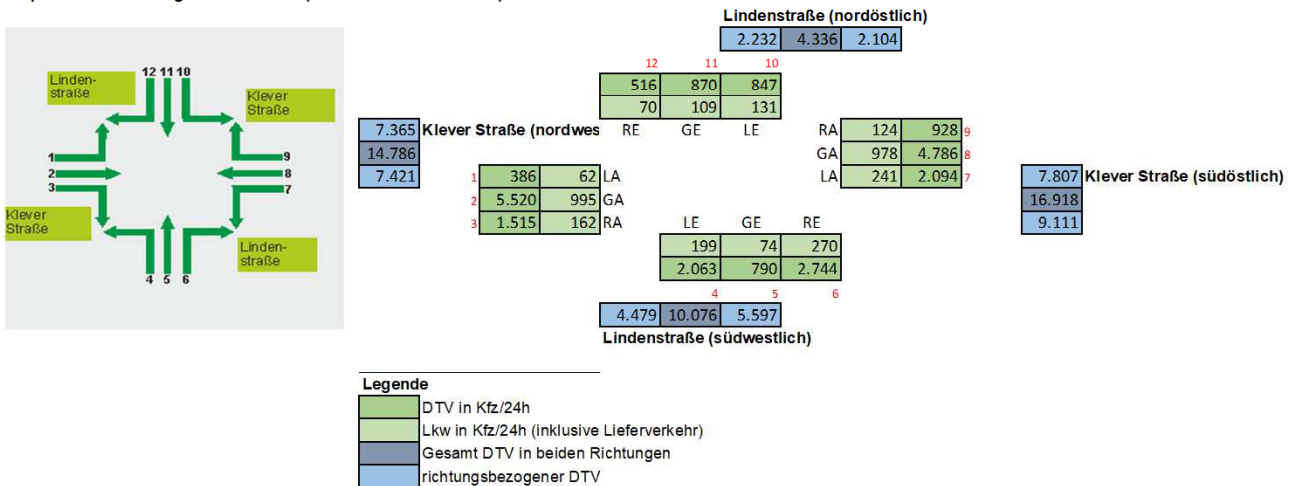

Graphische Darstellung der Spitzenstundenwerte morgens (7:00 - 8:00)

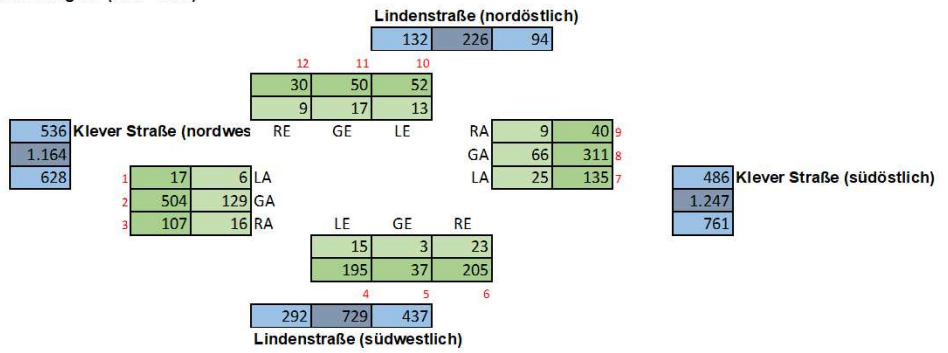
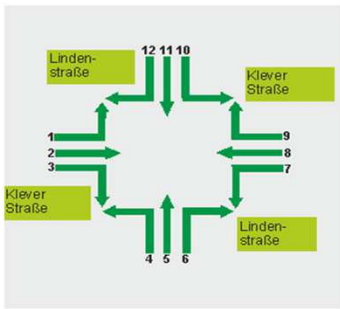

Graphische Darstellung der Spitzenstundenwerte nachmittags (17:00 - 18:00)

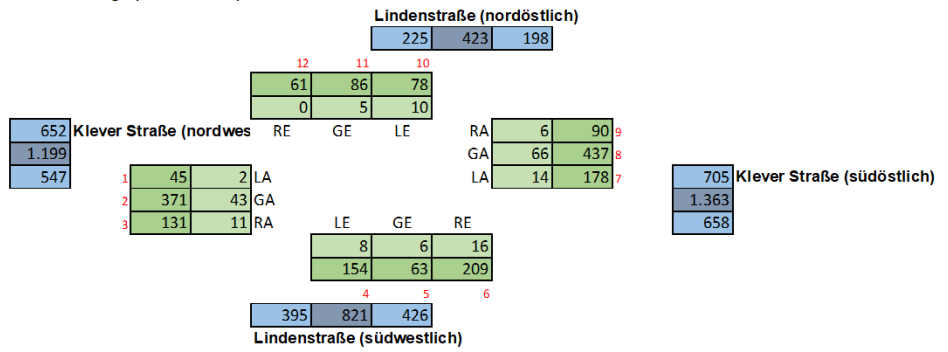

- Legende**
- Kfz/Spitzenstunde
 - Lkw/Spitzenstunde (inklusive Lieferverkehr)
 - Kfz/Spitzenstunde gesamt
 - Kfz/Spitzenstunde richtungsbezogen

Knotenpunkt 15

Egmontstraße/Kardinal-von-Galen-Straße/Blumenstraße

September 2019

2 mal 4 Stunden-Zählung

Datum der Zählung: Do. 17.09.2019

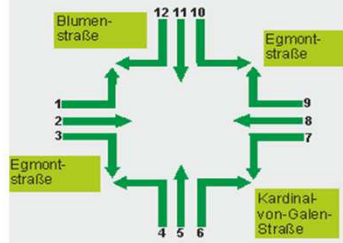

Intervall	Fz-Arten	Egmontstraße			Kardinal-von-Galen-Straße			Egmontstraße			Blumenstraße		
		LA	GA	RA	LE	GE	RE	LA	GE	RA	LE	GE	RE
		1	2	3	4	5	6	7	8	9	10	11	12
06:00 - 06:15	PKW	0	16	2	3	1	4	0	11	0	2	0	4
	KRAD	0	0	0	0	0	0	1	0	0	0	0	0
	LIEFERWAGEN	0	3	0	0	0	0	1	2	1	0	0	1
	LKW	0	1	0	0	0	0	0	1	0	0	0	0
06:15 - 06:30	PKW	0	27	2	4	2	12	4	33	0	0	2	4
	KRAD	0	0	0	0	0	0	0	0	0	0	0	0
	LIEFERWAGEN	0	1	0	0	0	0	2	7	0	0	0	0
	LKW	0	0	0	0	0	0	0	0	0	0	0	0
06:30 - 06:45	PKW	1	34	5	3	0	20	5	27	0	5	1	5
	KRAD	0	1	0	0	0	0	0	2	0	0	0	0
	LIEFERWAGEN	0	3	0	1	0	0	1	2	0	0	0	0
	LKW	0	2	0	0	0	0	1	0	0	0	0	0
06:45 - 07:00	PKW	0	41	2	3	3	17	4	29	1	4	2	4
	KRAD	0	1	0	0	0	0	0	0	0	0	0	0
	LIEFERWAGEN	0	8	1	0	0	2	1	5	0	0	1	0
	LKW	0	0	0	0	0	0	0	0	0	0	0	0
07:00 - 07:15	PKW	1	42	5	4	0	27	11	20	1	6	2	4
	KRAD	0	0	0	0	0	1	0	0	0	0	0	1
	LIEFERWAGEN	0	10	0	0	0	3	2	5	1	0	0	2
	LKW	0	2	0	1	0	1	0	2	0	0	0	0
07:15 - 07:30	PKW	4	70	4	7	3	26	6	53	4	9	4	4
	KRAD	0	0	0	0	0	0	0	0	0	0	0	0
	LIEFERWAGEN	0	9	2	0	1	2	1	8	0	0	1	0
	LKW	0	0	0	0	0	1	0	5	0	0	0	1
07:30 - 07:45	PKW	4	77	5	13	1	27	12	78	2	5	8	9
	KRAD	0	1	0	0	0	0	2	2	0	0	0	1
	LIEFERWAGEN	0	5	0	0	0	3	5	8	0	0	0	0
	LKW	0	5	0	0	0	0	0	3	0	0	0	0
07:45 - 08:00	PKW	3	81	12	9	1	19	32	70	3	10	9	11
	KRAD	0	0	0	1	0	1	0	1	0	0	0	0
	LIEFERWAGEN	0	5	2	1	0	2	3	10	0	0	0	0
	LKW	0	4	0	0	0	0	1	1	0	0	0	0
08:00 - 08:15	PKW	4	45	7	10	0	30	15	34	7	11	0	4
	KRAD	0	0	0	0	0	1	0	0	0	0	0	0
	LIEFERWAGEN	0	5	1	1	0	3	0	5	0	0	0	0
	LKW	0	1	0	0	0	0	0	1	0	0	0	0
08:15 - 08:30	PKW	2	50	8	5	2	18	13	30	2	12	3	4
	KRAD	0	0	0	0	0	0	0	0	0	0	0	0
	LIEFERWAGEN	0	4	0	0	0	1	2	6	0	0	0	0
	LKW	0	0	0	0	0	0	0	2	0	0	0	0
08:30 - 08:45	PKW	0	51	10	10	3	25	17	27	1	3	3	2
	KRAD	1	0	0	0	0	0	0	0	0	0	0	0
	LIEFERWAGEN	0	7	2	0	1	4	0	1	0	0	0	0
	LKW	0	0	0	0	0	0	0	2	0	0	0	0
08:45 - 09:00	PKW	1	57	6	3	5	32	20	31	4	4	5	5
	KRAD	0	0	0	0	0	0	0	0	0	0	0	0
	LIEFERWAGEN	1	0	1	2	0	2	0	4	1	0	0	0
	LKW	0	2	0	0	0	0	0	3	0	0	0	0
09:00 - 09:15	PKW	2	55	10	7	2	26	15	32	1	2	3	3
	KRAD	0	0	0	0	0	1	1	0	0	0	0	0
	LIEFERWAGEN	0	3	2	1	0	2	0	1	0	0	0	0
	LKW	0	1	0	0	0	0	1	1	1	0	0	0
09:15 - 09:30	PKW	1	39	12	11	1	29	20	30	2	1	2	4
	KRAD	0	2	0	0	0	0	0	1	0	0	0	0
	LIEFERWAGEN	0	6	0	0	0	2	0	3	0	0	0	1
	LKW	0	1	0	0	0	0	1	2	0	0	0	0
09:30 - 09:45	PKW	1	58	6	6	2	26	19	38	1	5	3	5
	KRAD	0	0	0	0	0	0	0	0	0	0	0	0
	LIEFERWAGEN	0	3	1	0	0	4	1	3	0	0	0	0
	LKW	0	2	0	0	0	1	1	1	0	0	0	0
09:45 - 10:00	PKW	1	29	7	8	3	33	19	33	1	2	2	4
	KRAD	0	0	0	0	0	0	0	1	0	0	0	0
	LIEFERWAGEN	0	3	1	0	0	6	1	5	0	0	0	0
	LKW	0	0	0	0	0	0	1	0	0	0	0	0

Knotenpunkt 15

Egmontstraße/Kardinal-von-Galen-Straße/Blumenstraße

Intervall	Fz-Arten	Egmontstraße			Kardinal-von-Galen-Straß			Egmontstraße			Blumenstraße		
		LA	GA	RA	LE	GE	RE	LA	GE	RA	LE	GE	RE
		1	2	3	4	5	6	7	8	9	10	11	12
Hochrechnung DTV													
Summe Kfz/4h (6-10)		27	873	116	114	31	414	242	682	34	81	51	83
Summe Pkw/4h (6-10)		26	777	103	107	29	375	216	583	30	81	49	78
Summe Lkw/4h (6-10)		1	96	13	7	2	39	26	99	4	0	2	5
Summe Kfz/4h (15-19)		70	1.301	158	224	81	628	336	980	70	69	64	76
Summe Pkw/4h (15-19)		63	1.182	154	214	78	577	317	912	66	65	61	65
Summe Lkw/4h (15-19)		7	119	4	10	3	51	19	68	4	4	3	11
DTV 24 Stunden		1	2	3	4	5	6	7	8	9	10	11	12
Morgens Kfz	21%	126	4079	542	533	145	1934	1131	3186	159	378	238	388
Morgens Lkw	30%	3	319	43	23	7	130	86	329	13	0	7	17
Nachmittags Kfz	33%	209	3890	472	670	242	1877	1005	2930	209	206	191	227
Nachmittags Lkw	27%	26	449	15	38	11	192	72	256	15	15	11	41
Mittelwert aus mo und na		168	3984	507	601	193	1906	1068	3058	184	292	215	308
Lkw-Anteil mit Lieferverkehr		15	384	29	30	9	161	79	293	14	8	9	29
Lkw-Anteil mit Lieferverkehr in %		9%	10%	6%	5%	5%	0%	7%	10%	8%	0%	4%	9%
davon mo	PKW	25	772	103	106	29	371	212	576	30	81	49	76
	KRAD	1	5	0	1	0	4	4	7	0	0	0	2
	LIEFERWAGEN	1	75	13	6	2	36	20	75	3	0	2	4
	LKW	0	21	0	1	0	3	6	24	1	0	0	1
davon	PKW	62	1.170	152	210	78	570	311	904	66	65	60	64
	KRAD	1	12	2	4	0	7	6	8	0	0	1	1
	LIEFERWAGEN	7	101	4	10	3	47	17	62	4	4	3	10
	LKW	0	18	0	0	0	4	2	6	0	0	0	1

Graphische Darstellung der DTV-Werte (Mittelwert aus mo und na):

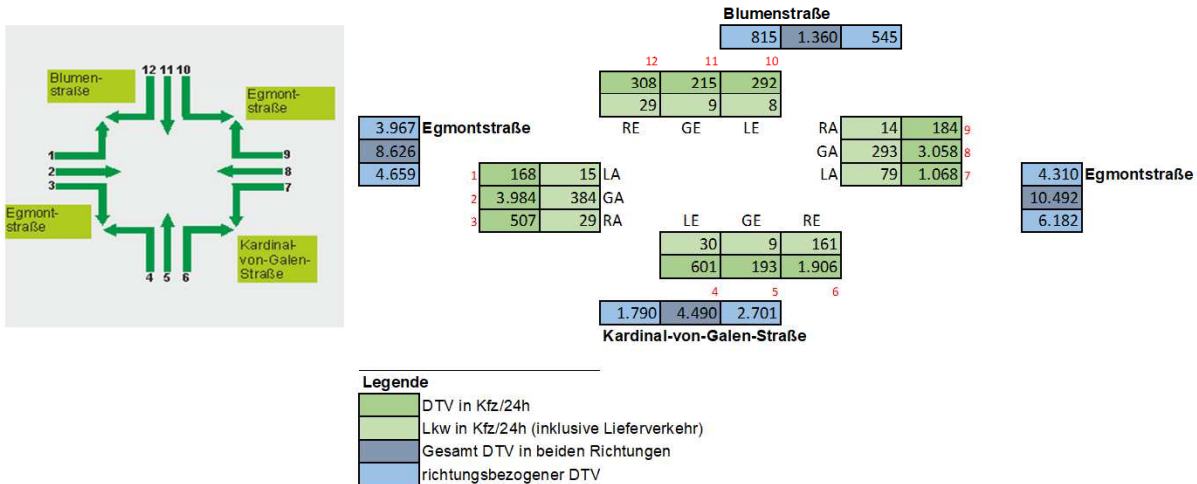

Graphische Darstellung der Spitzenstundenwerte morgens (7:00 - 8:00)

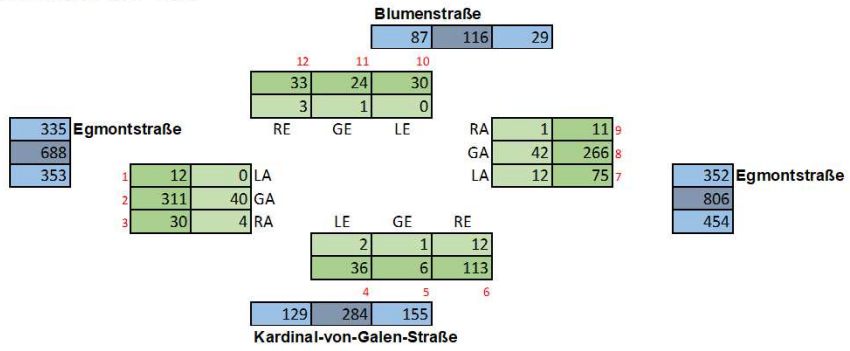
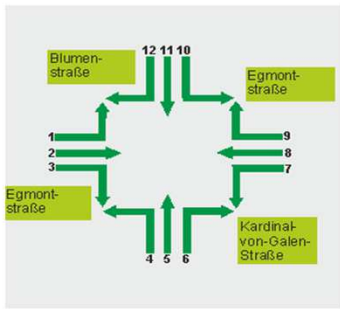

Graphische Darstellung der Spitzenstundenwerte nachmittags (17:00 - 18:00)

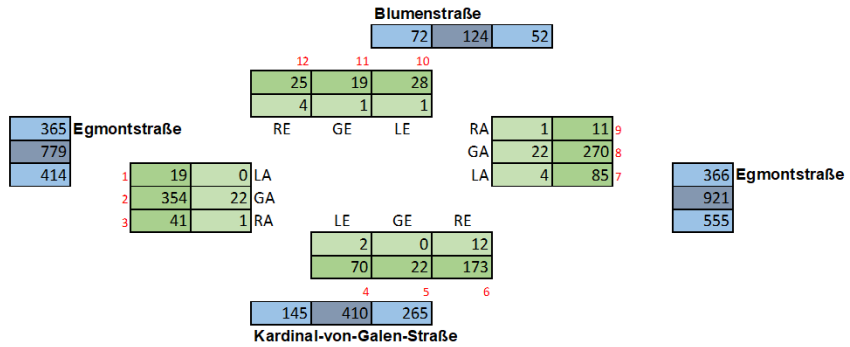

- Legende**
- Kfz/Spitzenstunde
 - Lkw/Spitzenstunde (inklusive Lieferverkehr)
 - Kfz/Spitzenstunde gesamt
 - Kfz/Spitzenstunde richtungsbezogen

Knotenpunkt 16

Grotendonker Straße (K13)/Rheinstraße (L491)/Schravelen (L491)

September 2019

2 mal 4 Stunden-Zählung

Datum der Zählung: Do. 17.09.2019

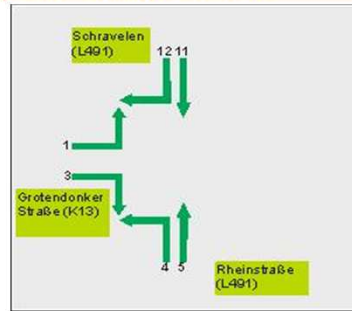

Intervall	Fz-Arten	Grotendonker Straße (K13)				Rheinstraße (L491)				Schravelen (L491)	
		LE	RE	LA	GA	LA	GA	GA	RA		
		1	3	4	5			11	12		
06:00 - 06:15	PKW	6	30	17	30					26	0
	KRAD	0	0	0	0					0	0
	LIEFERWAGEN	3	1	4	8					2	0
	LKW	3	1	1	6					3	0
06:15 - 06:30	PKW	3	19	19	45					27	0
	KRAD	0	0	0	0					0	0
	LIEFERWAGEN	0	8	0	4					5	0
	LKW	0	1	2	4					1	0
06:30 - 06:45	PKW	5	34	16	54					38	1
	KRAD	0	1	0	1					0	0
	LIEFERWAGEN	1	3	3	9					1	0
	LKW	1	3	0	0					3	0
06:45 - 07:00	PKW	3	42	33	54					49	1
	KRAD	0	1	0	0					0	0
	LIEFERWAGEN	2	12	7	6					3	0
	LKW	0	7	3	2					4	0
07:00 - 07:15	PKW	2	42	18	63					65	3
	KRAD	0	2	0	0					2	0
	LIEFERWAGEN	1	6	5	3					7	2
	LKW	1	2	4	4					3	0
07:15 - 07:30	PKW	2	39	28	66					79	1
	KRAD	0	1	1	0					2	0
	LIEFERWAGEN	0	6	3	7					5	0
	LKW	0	0	2	4					3	1
07:30 - 07:45	PKW	5	42	34	71					61	3
	KRAD	0	0	0	0					3	0
	LIEFERWAGEN	0	5	3	7					8	0
	LKW	3	2	3	2					7	1
07:45 - 08:00	PKW	4	34	17	59					74	4
	KRAD	0	1	1	0					0	0
	LIEFERWAGEN	2	8	5	8					7	0
	LKW	0	4	3	3					7	0
08:00 - 08:15	PKW	5	38	23	58					67	4
	KRAD	0	0	0	0					0	0
	LIEFERWAGEN	1	7	4	10					9	1
	LKW	0	7	5	3					7	0
08:15 - 08:30	PKW	3	31	16	49					47	2
	KRAD	0	0	0	0					1	0
	LIEFERWAGEN	1	6	2	4					7	0
	LKW	0	5	4	6					7	0
08:30 - 08:45	PKW	2	46	13	54					62	2
	KRAD	0	0	0	1					0	0
	LIEFERWAGEN	0	3	5	6					8	1
	LKW	1	4	2	7					9	0
08:45 - 09:00	PKW	3	36	23	63					49	1
	KRAD	0	0	0	0					1	0
	LIEFERWAGEN	0	3	4	5					3	0
	LKW	0	4	5	2					8	0
09:00 - 09:15	PKW	2	28	16	54					59	2
	KRAD	0	0	0	0					0	0
	LIEFERWAGEN	1	1	2	0					11	0
	LKW	0	1	7	9					10	0
09:15 - 09:30	PKW	2	37	18	37					65	2
	KRAD	0	0	0	0					0	0
	LIEFERWAGEN	0	1	0	2					7	0
	LKW	0	1	2	6					6	0
09:30 - 09:45	PKW	0	28	19	47					64	6
	KRAD	0	0	0	1					1	0
	LIEFERWAGEN	0	1	0	2					7	0
	LKW	0	2	4	8					4	0
09:45 - 10:00	PKW	1	27	20	57					63	2
	KRAD	0	0	0	0					0	0
	LIEFERWAGEN	0	2	3	7					2	0
	LKW	0	1	5	6					3	0

Intervall	Fz-Arten	Arntendonker Straße (K13)				Rheinstraße (L491)				Schravelen (L491)			
		LE	RE	LA	GA					GA	RA		
		1	3	4	5					11	12		
15:00 - 15:15	PKW	0	23	34	90					56	6		
	KRAD	0	0	0	0					2	1		
	LIEFERWAGEN	0	6	5	10					8	0		
	LKW	0	1	2	8					4	0		
15:15 - 15:30	PKW	2	17	39	73					80	4		
	KRAD	0	0	0	1					3	0		
	LIEFERWAGEN	1	3	5	2					8	0		
	LKW	0	2	2	5					7	0		
15:30 - 15:45	PKW	4	27	35	63					89	3		
	KRAD	0	0	0	1					0	0		
	LIEFERWAGEN	0	4	7	10					6	0		
	LKW	0	2	2	1					4	0		
15:45 - 16:00	PKW	3	31	33	93					74	3		
	KRAD	0	0	1	4					0	1		
	LIEFERWAGEN	1	7	7	4					5	1		
	LKW	0	2	4	5					4	0		
16:00 - 16:15	PKW	1	30	50	83					78	6		
	KRAD	0	0	1	3					0	0		
	LIEFERWAGEN	0	2	5	5					10	1		
	LKW	0	1	7	3					10	0		
16:15 - 16:30	PKW	4	28	51	87					92	4		
	KRAD	0	0	0	1					0	0		
	LIEFERWAGEN	0	2	12	6					11	0		
	LKW	0	2	2	3					6	0		
16:30 - 16:45	PKW	2	44	50	95					63	5		
	KRAD	0	0	1	0					0	0		
	LIEFERWAGEN	0	5	10	4					11	0		
	LKW	1	3	0	5					3	0		
16:45 - 17:00	PKW	2	47	45	87					87	3		
	KRAD	0	0	0	2					1	0		
	LIEFERWAGEN	1	1	5	10					9	1		
	LKW	0	2	2	4					2	0		
17:00 - 17:15	PKW	2	22	60	109					78	3		
	KRAD	0	0	1	0					0	0		
	LIEFERWAGEN	0	3	4	4					7	0		
	LKW	0	4	2	4					3	0		
17:15 - 17:30	PKW	2	40	71	102					65	6		
	KRAD	0	0	1	0					2	0		
	LIEFERWAGEN	0	4	6	9					4	0		
	LKW m.A.	0	0	1	2					3	0		
17:30 - 17:45	PKW	3	28	49	97					94	2		
	KRAD	0	0	0	0					0	0		
	LIEFERWAGEN	0	1	4	4					8	0		
	LKW	0	1	0	1					3	0		
17:45 - 18:00	PKW	4	29	49	106					78	2		
	KRAD	0	1	1	0					0	0		
	LIEFERWAGEN	0	0	2	5					5	0		
	LKW	0	1	0	7					2	0		
18:00 - 18:15	PKW	2	24	36	103					96	2		
	KRAD	0	2	0	0					0	0		
	LIEFERWAGEN	0	2	3	1					2	0		
	LKW	0	2	0	2					0	0		
18:15 - 18:30	PKW	4	31	44	63					59	5		
	KRAD	0	0	0	0					1	0		
	LIEFERWAGEN	0	1	0	5					1	2		
	LKW	0	1	1	3					1	0		
18:30 - 18:45	PKW	0	32	36	76					82	5		
	KRAD	0	0	0	0					0	0		
	LIEFERWAGEN	0	1	2	5					2	1		
	LKW	1	1	0	1					3	0		
18:45 - 19:00	PKW	4	21	31	78					51	5		
	KRAD	0	2	0	0					0	0		
	LIEFERWAGEN	0	2	2	4					1	0		
	LKW	0	0	0	4					2	0		

Knotenpunkt 16

Grotendonker Straße (K13)/Rheinstraße (L491)/Schravelen (L491)

Intervall	Fz-Arten	Grotendonker Straße (K13)		Rheinstraße (L491)		Schravelen (L491)			
		LE	RE	LA	GA			GA	RA
		1	3	4	5			11	12
Hochrechnung DTV									
Summe Kfz/4h (6-10)		69	677	434	1.024			1.082	40
Summe Pkw/4h (6-10)		48	559	332	864			905	34
Summe Lkw/4h (6-10)		21	118	102	160			177	6
Summe Kfz/4h (15-19)		44	548	823	1.563			1.386	72
Summe Pkw/4h (15-19)		39	479	719	1.417			1.231	66
Summe Lkw/4h (15-19)		5	69	103	144			152	6
DTV 24 Stunden		1	3	4	5			11	12
Morgens Kfz	21%	322	3163	2028	4784			5055	187
Morgens Lkw	30%	70	392	339	532			588	20
Nachmittags Kfz	33%	132	1638	2460	4673			4144	215
Nachmittags Lkw	27%	19	260	388	543			573	23
Mittelwert aus mo und na		227	2401	2244	4729			4599	201
Lkw-Anteil mit Lieferverkehr		44	326	364	537			581	21
Lkw-Anteil mit Lieferverkehr in %		20%	14%	16%	11%			13%	11%
davon mo	PKW	48	553	330	861			895	34
	KRAD	0	6	2	3			10	0
	LIEFERWAGEN	12	73	50	88			92	4
	LKW	9	45	52	72			85	2
davon	PKW	39	474	713	1.405			1.222	64
	KRAD	0	5	6	12			9	2
	LIEFERWAGEN	3	44	79	88			98	6
	LKW	2	25	24	56			54	0

Graphische Darstellung der DTV-Werte (Mittelwert aus mo und na):

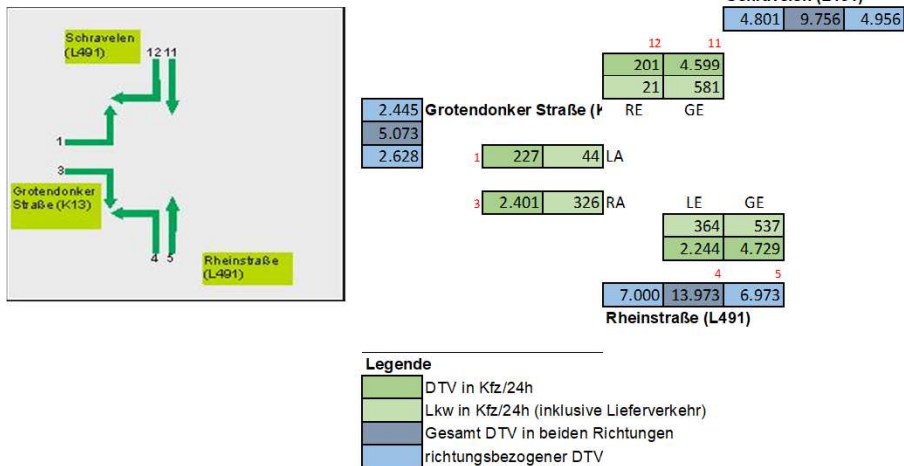

Graphische Darstellung der Spitzenstundenwerte morgens (7:00 - 8:00)

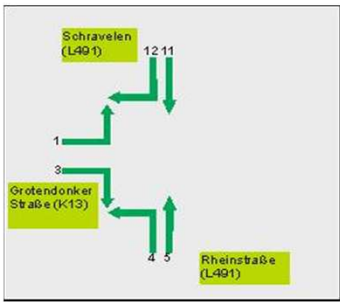

		Schravelen (L491)			
		12 11		348 665 317	
		15 333			
		4 47			
Grotendonker Straße (K13)		RE GE			
142 356 214					
		1 20 7 LA			
		3 194 33 RA			
				LE GE	
				28 38	
				127 297	
				4 5	
				527 951 424	
				Rheinstraße (L491)	

Graphische Darstellung der Spitzenstundenwerte nachmittags (17:00 - 18:00)

		Schravelen (L491)			
		12 11		365 826 461	
		13 352			
		0 35			
Grotendonker Straße (K13)		RE GE			
264 409 145					
		1 11 0 LA			
		3 134 10 RA			
				LE GE	
				19 36	
				251 450	
				4 5	
				486 1.187 701	
				Rheinstraße (L491)	

- Legende**
- Kfz/Spitzenstunde
 - Lkw/Spitzenstunde (inklusive Lieferverkehr)
 - Kfz/Spitzenstunde gesamt
 - Kfz/Spitzenstunde richtungsbezogen

Beide Richtungen								
Querschnittszählungn	Uhrzeit	Anzahl Fahr-zeuge	Pkw-Ein-heiten	PKW	KRAD	LIEFER	LKW	LKW-Anteil
Q1 - Geldener Straße								
Donnerstag 19.09.2019	0	5	5	4	1	0	0	0,0%
	1	1	1	1	0	0	0	0,0%
	2	2	2	2	0	0	0	0,0%
	3	5	5	5	0	0	0	0,0%
	4	11	11	10	0	1	0	9,1%
	5	74	75	62	3	5	4	12,2%
	6	142	143	131	1	8	2	7,0%
	7	307	310	274	4	20	9	9,4%
	8	270	272	247	1	17	5	8,1%
	9	237	243	220	0	6	11	7,2%
	10	226	232	199	2	12	13	11,1%
	11	255	259	231	1	14	9	9,0%
	12	281	282	251	3	23	4	9,6%
	13	281	282	257	3	17	4	7,5%
	14	287	286	267	6	11	3	4,9%
	15	331	331	304	3	21	3	7,3%
	16	402	403	380	3	15	4	4,7%
	17	367	369	349	2	10	6	4,4%
	18	305	302	289	8	6	2	2,6%
	19	175	175	164	2	8	1	5,1%
	20	113	114	108	0	3	2	4,4%
	21	95	95	92	1	2	0	2,1%
	22	50	50	50	0	0	0	0,0%
23	16	16	15	1	0	0	0,0%	
		4.238	4.257	3.912	45	199	82	
4h morgens		956	967	872	6	51	27	78
Anteil 4h-Werte morgens auf DTV		23%	23%	22%	13%	26%	33%	28%
4h nachmittags		1.405	1.405	1.322	16	52	15	67
Anteil 4h-Werte nachmittags auf DTV		33%	33%	34%	36%	26%	18%	24%
Querschnittszählungn	Uhrzeit	Anzahl Fahr-zeuge	Pkw-Ein-heiten	PKW	KRAD	LIEFER	LKW	LKW-Anteil
Q2 - Sonnenstraße								
Donnerstag 19.09.2019	0	6	6	6	0	0	0	0,0%
	1	1	1	1	0	0	0	0,0%
	2	0	0	0	0	0	0	0,0%
	3	5	5	5	0	0	0	0,0%
	4	11	11	11	0	0	0	0,0%
	5	64	65	61	0	1	2	4,7%
	6	137	138	124	1	10	2	8,8%
	7	255	256	240	2	10	3	5,1%
	8	248	249	235	2	8	3	4,4%
	9	201	203	178	3	14	6	10,0%
	10	196	197	186	1	7	2	4,6%
	11	213	214	198	3	8	4	5,6%
	12	240	240	213	5	17	5	9,2%
	13	217	219	196	2	13	6	8,8%
	14	233	233	220	1	11	1	5,2%
	15	261	261	243	2	15	1	6,1%
	16	325	324	314	2	9	0	2,8%
	17	307	308	296	0	10	1	3,6%
	18	298	295	277	6	15	0	5,0%
	19	207	207	199	1	6	1	3,4%
	20	128	128	124	1	2	1	2,3%
	21	61	61	60	1	0	0	0,0%
	22	53	53	53	0	0	0	0,0%
23	14	14	14	0	0	0	0,0%	
		3.681	3.684	3.454	33	156	38	
4h morgens		841	844	777	8	42	14	56
Anteil 4h-Werte morgens auf DTV		23%	23%	22%	24%	27%	37%	29%
4h nachmittags		1.191	1.187	1.130	10	49	2	51
Anteil 4h-Werte nachmittags auf DTV		32%	32%	33%	30%	31%	5%	26%

Beide Richtungen								
Querschnittszählungn	Uhrzeit	Anzahl Fahr-zeuge	Pkw-Ein-heiten	PKW	KRAD	LIEFER	LKW	LKW-Anteil
Q3 - Koxheidestraße								
Donnerstag 19.09.2019	0	2	2	2	0	0	0	0,0%
	1	1	1	1	0	0	0	0,0%
	2	0	0	0	0	0	0	0,0%
	3	0	0	0	0	0	0	0,0%
	4	3	3	3	0	0	0	0,0%
	5	21	22	19	0	1	1	9,5%
	6	44	44	38	0	6	0	13,6%
	7	145	146	133	1	8	3	7,6%
	8	123	124	114	0	8	1	7,3%
	9	93	94	84	1	6	2	8,6%
	10	86	86	83	0	3	0	3,5%
	11	104	105	94	0	8	2	9,6%
	12	98	99	89	0	8	1	9,2%
	13	113	114	103	1	6	3	8,0%
	14	105	104	98	2	5	0	4,8%
	15	148	148	139	1	8	0	5,4%
	16	138	139	131	0	5	2	5,1%
	17	133	132	125	3	5	0	3,8%
	18	131	131	127	0	4	0	3,1%
	19	110	109	105	2	3	0	2,7%
	20	68	68	67	1	0	0	0,0%
	21	38	38	37	0	1	0	2,6%
	22	23	23	23	0	0	0	0,0%
	23	7	7	7	0	0	0	0,0%
		1.734	1.736	1.622	12	85	15	
4h morgens		405	407	369	2	28	6	34
Anteil 4h-Werte morgens auf DTV		23%	23%	23%	17%	33%	40%	34%
4h nachmittags		550	549	522	4	22	2	24
Anteil 4h-Werte nachmittags auf DTV		32%	32%	32%	33%	26%	13%	24%
Querschnittszählungn	Uhrzeit	Anzahl Fahr-zeuge	Pkw-Ein-heiten	PKW	KRAD	LIEFER	LKW	LKW-Anteil
Q4 - Biegstraße								
Donnerstag 19.09.2019	0	2	2	2	0	0	0	0,0%
	1	2	2	2	0	0	0	0,0%
	2	0	0	0	0	0	0	0,0%
	3	1	1	1	0	0	0	0,0%
	4	6	5	3	3	0	0	0,0%
	5	27	27	26	0	1	0	3,7%
	6	36	36	33	0	3	0	8,3%
	7	191	192	174	1	13	3	8,4%
	8	103	103	101	0	2	0	1,9%
	9	103	104	95	0	6	2	7,8%
	10	97	98	87	0	9	1	10,3%
	11	118	119	109	1	6	2	6,8%
	12	109	110	101	0	6	2	7,3%
	13	108	109	104	0	3	1	3,7%
	14	166	167	154	0	11	1	7,2%
	15	226	226	218	1	7	0	3,1%
	16	180	179	166	2	12	0	6,7%
	17	166	164	157	5	4	0	2,4%
	18	158	158	149	1	8	0	5,1%
	19	109	108	106	2	1	0	0,9%
	20	69	69	69	0	0	0	0,0%
	21	48	48	46	1	1	0	2,1%
	22	31	31	31	0	0	0	0,0%
	23	10	10	10	0	0	0	0,0%
		2.066	2.064	1.944	17	93	12	
4h morgens		433	435	403	1	24	5	29
Anteil 4h-Werte morgens auf DTV		21%	21%	21%	6%	26%	42%	28%
4h nachmittags		730	726	690	9	31	0	31
Anteil 4h-Werte nachmittags auf DTV		35%	35%	35%	53%	33%	0%	30%

Beide Richtungen								
Querschnittszählungn	Uhrzeit	Anzahl Fahr-zeuge	Pkw-Ein-heiten	PKW	KRAD	LIEFER	LKW	LKW-Anteil
Q5 - Händelstraße								
Donnerstag 19.09.2019	0	7	7	7	0	0	0	0,0%
	1	5	5	5	0	0	0	0,0%
	2	1	1	1	0	0	0	0,0%
	3	2	2	2	0	0	0	0,0%
	4	16	16	14	0	2	0	12,5%
	5	54	54	53	1	0	0	0,0%
	6	104	105	94	2	5	3	7,7%
	7	197	198	178	0	18	1	9,6%
	8	129	130	118	0	10	1	8,5%
	9	116	118	109	0	4	3	6,0%
	10	117	117	113	0	4	0	3,4%
	11	127	128	122	0	4	1	3,9%
	12	147	147	136	2	8	1	6,1%
	13	145	145	131	1	12	1	9,0%
	14	143	143	137	0	6	0	4,2%
	15	179	178	166	2	11	0	6,1%
	16	244	245	230	2	9	3	4,9%
	17	270	269	256	3	11	0	4,1%
	18	231	231	223	1	7	0	3,0%
	19	157	156	149	3	4	1	3,2%
	20	85	85	83	1	1	0	1,2%
	21	49	49	47	0	2	0	4,1%
	22	48	48	48	0	0	0	0,0%
	23	18	18	18	0	0	0	0,0%
		2.591	2.590	2.440	18	118	15	
4h morgens		546	549	499	2	37	8	45
Anteil 4h-Werte morgens auf DTV		21%	21%	20%	11%	31%	53%	34%
4h nachmittags		924	922	875	8	38	3	41
Anteil 4h-Werte nachmittags auf DTV		36%	36%	36%	44%	32%	20%	31%
Querschnittszählungn	Uhrzeit	Anzahl Fahr-zeuge	Pkw-Ein-heiten	PKW	KRAD	LIEFER	LKW	LKW-Anteil
Q6 - Weezer Straße								
Donnerstag 19.09.2019	0	2	2	2	0	0	0	0,0%
	1	2	2	2	0	0	0	0,0%
	2	2	2	2	0	0	0	0,0%
	3	4	4	4	0	0	0	0,0%
	4	4	4	4	0	0	0	0,0%
	5	36	36	34	0	2	0	5,6%
	6	49	51	43	0	3	3	12,2%
	7	127	128	105	2	16	4	15,7%
	8	90	90	83	1	5	1	6,7%
	9	55	57	51	0	1	3	7,3%
	10	64	64	57	0	7	0	10,9%
	11	85	88	74	1	4	6	11,8%
	12	83	84	75	0	6	2	9,6%
	13	86	88	74	1	7	4	12,8%
	14	91	92	84	0	6	1	7,7%
	15	109	109	92	2	14	1	13,8%
	16	131	131	118	1	11	1	9,2%
	17	124	122	114	4	6	0	4,8%
	18	93	93	87	1	5	0	5,4%
	19	77	77	72	2	1	2	3,9%
	20	42	42	40	1	0	1	2,4%
	21	26	26	26	0	0	0	0,0%
	22	13	13	13	0	0	0	0,0%
	23	11	11	11	0	0	0	0,0%
		1.406	1.413	1.267	16	94	29	
4h morgens		321	325	282	3	25	11	36
Anteil 4h-Werte morgens auf DTV		23%	23%	22%	19%	27%	38%	29%
4h nachmittags		457	454	411	8	36	2	38
Anteil 4h-Werte nachmittags auf DTV		33%	32%	32%	50%	38%	7%	31%

Beide Richtungen								
Querschnittszählungn	Uhrzeit	Anzahl Fahr-zeuge	Pkw-Ein-heiten	PKW	KRAD	LIEFER	LKW	LKW-Anteil
Q7 - Feldstraße								
Donnerstag 19.09.2019	0	8	8	7	1	0	0	0,0%
	1	0	0	0	0	0	0	0,0%
	2	3	3	3	0	0	0	0,0%
	3	2	2	2	0	0	0	0,0%
	4	5	5	5	0	0	0	0,0%
	5	41	41	35	0	6	0	14,6%
	6	105	108	91	2	5	7	11,4%
	7	233	237	198	4	19	12	13,3%
	8	196	200	165	0	24	7	15,8%
	9	234	239	195	3	24	12	15,4%
	10	272	274	239	5	19	9	10,3%
	11	255	258	219	5	21	10	12,2%
	12	320	323	282	6	21	11	10,0%
	13	297	302	263	2	21	11	10,8%
	14	326	330	295	2	20	9	8,9%
	15	309	309	273	8	20	8	9,1%
	16	357	359	316	8	22	11	9,2%
	17	345	341	318	11	13	3	4,6%
	18	270	266	257	9	3	1	1,5%
	19	171	168	163	6	2	0	1,2%
	20	100	100	99	0	1	0	1,0%
	21	69	69	68	1	0	0	0,0%
	22	41	41	41	0	0	0	0,0%
23	12	12	12	0	0	0	0,0%	
		3.971	3.990	3.546	73	241	111	
4h morgens		768	783	649	9	72	38	110
Anteil 4h-Werte morgens auf DTV		19%	20%	18%	12%	30%	34%	31%
4h nachmittags		1.281	1.275	1.164	36	58	23	81
Anteil 4h-Werte nachmittags auf DTV		32%	32%	33%	49%	24%	21%	23%
Querschnittszählungn	Uhrzeit	Anzahl Fahr-zeuge	Pkw-Ein-heiten	PKW	KRAD	LIEFER	LKW	LKW-Anteil
Q8 - Willibrordstraße								
Donnerstag 19.09.2019	0	2	2	2	0	0	0	0,0%
	1	0	0	0	0	0	0	0,0%
	2	2	2	1	1	0	0	0,0%
	3	0	0	0	0	0	0	0,0%
	4	1	1	1	0	0	0	0,0%
	5	4	4	3	1	0	0	0,0%
	6	7	7	4	0	3	0	42,9%
	7	33	34	23	1	6	3	27,3%
	8	31	31	25	1	4	1	16,1%
	9	43	43	37	0	6	0	14,0%
	10	48	48	37	2	7	2	18,8%
	11	52	53	45	1	4	2	11,5%
	12	43	44	38	0	3	2	11,6%
	13	37	37	34	1	1	1	5,4%
	14	37	37	31	0	6	0	16,2%
	15	51	51	49	0	2	0	3,9%
	16	56	55	51	2	3	0	5,4%
	17	53	53	50	0	3	0	5,7%
	18	25	25	25	0	0	0	0,0%
	19	11	12	10	0	0	1	9,1%
	20	11	11	10	1	0	0	0,0%
	21	11	11	10	1	0	0	0,0%
	22	2	2	1	0	1	0	50,0%
23	1	1	1	0	0	0	0,0%	
		561	561	488	12	49	12	
4h morgens		114	115	89	2	19	4	23
Anteil 4h-Werte morgens auf DTV		20%	20%	18%	17%	39%	33%	38%
4h nachmittags		185	184	175	2	8	0	8
Anteil 4h-Werte nachmittags auf DTV		33%	33%	36%	17%	16%	0%	13%

Beide Richtungen								
Querschnittszählungn	Uhrzeit	Anzahl Fahr-zeuge	Pkw-Ein-heiten	PKW	KRAD	LIEFER	LKW	LKW-Anteil
Q9 - Busmannstraße								
Donnerstag 19.09.2019	0	2	2	2	0	0	0	0,0%
	1	4	4	3	0	1	0	25,0%
	2	1	1	0	1	0	0	0,0%
	3	2	3	1	0	0	1	50,0%
	4	1	1	1	0	0	0	0,0%
	5	6	6	6	0	0	0	0,0%
	6	10	12	6	0	1	3	40,0%
	7	34	36	23	0	8	3	32,4%
	8	48	49	42	0	5	1	12,5%
	9	59	59	51	1	7	0	11,9%
	10	70	68	55	4	11	0	15,7%
	11	79	80	67	0	10	2	15,2%
	12	81	82	66	0	14	1	18,5%
	13	41	41	37	1	3	0	7,3%
	14	53	53	46	1	6	0	11,3%
	15	68	67	58	3	7	0	10,3%
	16	72	72	64	1	7	0	9,7%
	17	103	102	91	3	9	0	8,7%
	18	73	73	71	1	1	0	1,4%
	19	29	29	28	0	1	0	3,4%
	20	23	23	22	0	1	0	4,3%
	21	16	16	16	0	0	0	0,0%
	22	7	7	7	0	0	0	0,0%
	23	2	2	2	0	0	0	0,0%
		884	882	765	16	92	11	
4h morgens		151	154	122	1	21	7	28
Anteil 4h-Werte morgens auf DTV		17%	17%	16%	6%	23%	64%	27%
4h nachmittags		316	312	284	8	24	0	24
Anteil 4h-Werte nachmittags auf DTV		36%	35%	37%	50%	26%	0%	23%
Querschnittszählungn	Uhrzeit	Anzahl Fahr-zeuge	Pkw-Ein-heiten	PKW	KRAD	LIEFER	LKW	LKW-Anteil
Q10 - Wettener Straße								
Donnerstag 19.09.2019	0	10	9	8	2	0	0	0,0%
	1	6	6	6	0	0	0	0,0%
	2	4	4	4	0	0	0	0,0%
	3	0	0	0	0	0	0	0,0%
	4	14	15	11	0	2	1	21,4%
	5	66	65	59	3	4	0	6,1%
	6	128	131	112	1	9	6	11,7%
	7	241	244	201	3	28	9	15,4%
	8	206	213	171	1	19	15	16,5%
	9	222	237	169	0	24	29	23,9%
	10	246	255	205	2	19	20	15,9%
	11	242	251	188	1	35	18	21,9%
	12	232	244	176	2	28	26	23,3%
	13	227	236	187	2	18	20	16,7%
	14	270	276	206	6	40	18	21,5%
	15	256	266	201	3	29	23	20,3%
	16	330	338	270	4	37	19	17,0%
	17	314	312	271	11	25	7	10,2%
	18	240	237	219	8	12	1	5,4%
	19	145	144	134	4	5	2	4,8%
	20	120	120	112	0	8	0	6,7%
	21	75	74	70	3	2	0	2,7%
	22	40	40	40	0	0	0	0,0%
	23	18	18	17	1	0	0	0,0%
		3.652	3.731	3.037	57	344	214	
4h morgens		797	824	653	5	80	59	139
Anteil 4h-Werte morgens auf DTV		22%	22%	22%	9%	23%	28%	25%
4h nachmittags		1.140	1.152	961	26	103	50	153
Anteil 4h-Werte nachmittags auf DTV		31%	31%	32%	46%	30%	23%	27%

Beide Richtungen								
Querschnittszählungn	Uhrzeit	Anzahl Fahr-zeuge	Pkw-Ein-heiten	PKW	KRAD	LIEFER	LKW	LKW-Anteil
Q11 - Hoogeweg								
Dienstag 17.09.2019	0	7	8	5	0	1	1	28,6%
	1	3	3	1	0	2	0	66,7%
	2	2	2	2	0	0	0	0,0%
	3	12	13	7	0	3	2	41,7%
	4	12	13	9	0	2	1	25,0%
	5	80	81	73	0	6	1	8,8%
	6	156	158	125	1	26	4	19,2%
	7	277	283	213	5	43	16	21,3%
	8	259	268	201	0	41	17	22,4%
	9	154	160	125	1	16	12	18,2%
	10	171	178	128	3	24	16	23,4%
	11	196	203	154	2	24	16	20,4%
	12	217	225	168	3	27	19	21,2%
	13	217	226	172	1	26	18	20,3%
	14	208	215	168	1	24	15	18,8%
	15	275	279	220	3	41	11	18,9%
	16	405	409	329	9	50	17	16,5%
	17	335	339	298	4	22	11	9,9%
	18	175	178	157	0	13	5	10,3%
	19	122	124	106	1	11	4	12,3%
	20	71	73	66	0	2	3	7,0%
	21	40	40	36	2	1	1	5,0%
	22	18	18	18	0	0	0	0,0%
23	9	10	8	0	0	1	11,1%	
		3.421	3.499	2.789	36	405	191	
4h morgens		846	867	664	7	126	49	175
Anteil 4h-Werte morgens auf DTV		25%	25%	24%	19%	31%	26%	29%
4h nachmittags		1.190	1.204	1.004	16	126	44	170
Anteil 4h-Werte nachmittags auf DTV		35%	34%	36%	44%	31%	23%	29%
Querschnittszählungn	Uhrzeit	Anzahl Fahr-zeuge	Pkw-Ein-heiten	PKW	KRAD	LIEFER	LKW	LKW-Anteil
Q12 - Nordstraße								
Donnerstag 19.09.2019	0	3	3	3	0	0	0	0,0%
	1	0	0	0	0	0	0	0,0%
	2	0	0	0	0	0	0	0,0%
	3	0	0	0	0	0	0	0,0%
	4	12	12	12	0	0	0	0,0%
	5	40	40	35	0	5	0	12,5%
	6	50	50	47	0	3	0	6,0%
	7	94	95	82	1	9	2	11,7%
	8	74	75	62	0	10	2	16,2%
	9	69	69	55	2	11	1	17,4%
	10	70	70	53	2	13	2	21,4%
	11	79	80	71	1	5	2	8,9%
	12	81	81	72	0	9	0	11,1%
	13	74	75	64	1	7	2	12,2%
	14	88	89	71	2	12	3	17,0%
	15	109	109	92	1	15	1	14,7%
	16	133	135	118	0	12	3	11,3%
	17	130	130	115	1	14	0	10,8%
	18	108	107	95	3	9	1	9,3%
	19	84	84	80	0	4	0	4,8%
	20	47	47	45	0	2	0	4,3%
	21	32	32	31	0	1	0	3,1%
	22	15	15	15	0	0	0	0,0%
23	5	5	5	0	0	0	0,0%	
		1.397	1.400	1.223	14	141	19	
4h morgens		287	288	246	3	33	5	38
Anteil 4h-Werte morgens auf DTV		21%	21%	20%	21%	23%	26%	24%
4h nachmittags		480	480	420	5	50	5	55
Anteil 4h-Werte nachmittags auf DTV		34%	34%	34%	36%	35%	26%	34%

Beide Richtungen								
Querschnittszählung	Uhrzeit	Anzahl Fahr-zeuge	Pkw-Ein-heiten	PKW	KRAD	LIEFER	LKW	LKW-Anteil
Q13 - Wasserstraße								
Donnerstag 19.09.2019	0	2	2	2	0	0	0	0,0%
	1	2	2	2	0	0	0	0,0%
	2	0	0	0	0	0	0	0,0%
	3	1	1	1	0	0	0	0,0%
	4	3	3	3	0	0	0	0,0%
	5	22	22	20	0	2	0	9,1%
	6	31	31	29	0	2	0	6,5%
	7	67	67	57	2	7	1	11,9%
	8	58	60	47	0	8	3	19,0%
	9	52	54	44	0	5	3	15,4%
	10	47	47	41	0	6	0	12,8%
	11	53	53	47	0	6	0	11,3%
	12	50	50	49	0	1	0	2,0%
	13	76	77	71	0	4	1	6,6%
	14	70	71	67	0	2	1	4,3%
	15	70	71	64	0	5	1	8,6%
	16	84	84	77	0	7	0	8,3%
	17	91	91	82	1	8	0	8,8%
	18	83	83	80	0	3	0	3,6%
	19	71	71	67	0	4	0	5,6%
	20	30	30	30	0	0	0	0,0%
	21	22	22	21	0	1	0	4,5%
	22	12	12	12	0	0	0	0,0%
23	4	4	4	0	0	0	0,0%	
		1.001	1.005	917	3	71	10	81
4h morgens		208	211	177	2	22	7	29
Anteil 4h-Werte morgens auf DTV		21%	21%	19%	67%	31%	70%	36%
4h nachmittags		328	328	303	1	23	1	24
Anteil 4h-Werte nachmittags auf DTV		33%	33%	33%	33%	32%	10%	30%